

TEXTRON Lycoming AIRCRAFT ENGINES

O-360-J2A Wide Cylinder Flange Crankcase Model Engine

PARTS CATALOG PC-306-11

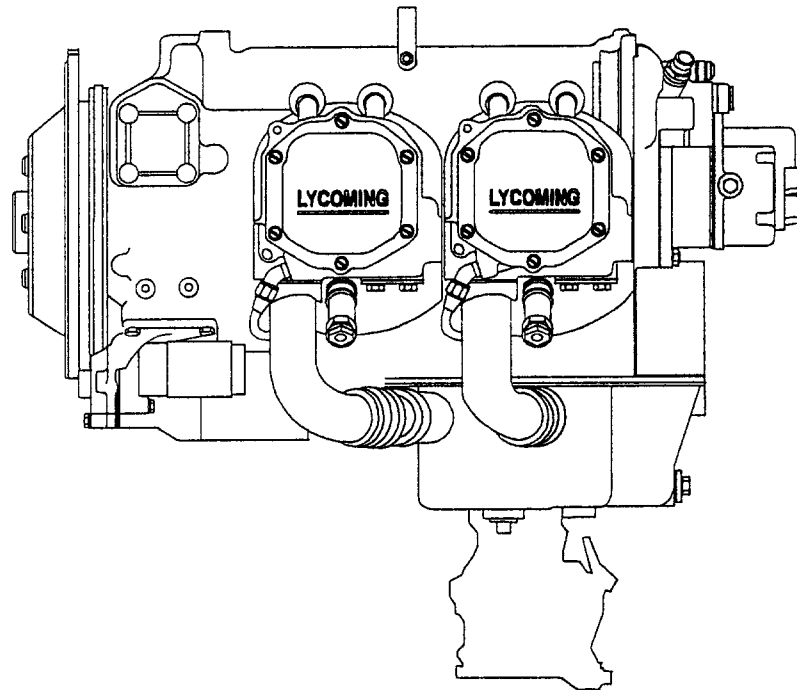

JANUARY 1996

TEXTRON Lycoming

652 Oliver Street
Williamsport, PA 17701 U.S.A.
717/323-6181

TECHNICAL PUBLICATION REVISION

REVISION No.	PUBLICATION	PUBLICATION No.	PUBLICATION DATE
PC-306-11A	O-360-J2A Engines	PC-306-11	JANUARY, 1996
This page(s) furnished herewith are intended to replace the corresponding page(s) of the publication indicated above.			
Previous revisions to this publication	This revision consists of: -		
<u>None</u>	<u>September, 1998</u> Page 1-1 Figure 1. Text Change Page 6-5 Figure 21. Text Change		

This illustrated parts catalog contains a complete parts listing for the Textron Lycoming O-360-J2A wide cylinder flange crankcase model aircraft engines.

Major assembly and sub-assembly parts of the engines are listed in the Group Assembly sections in the general sequence of engine build up.

A Service Kits section and Oversize and Undersize Parts List are included to aid in ordering parts as necessary during overhaul.

The Numerical Index is provided for convenience in finding parts when only the part number is known.

Parts coverage of Vendor Accessories used on Textron Lycoming engines may be found in the appropriate Vendor's Parts Catalog. A list of addresses of where to obtain these publications appears in the latest edition of Service Letter No. L114.

NOTE

The illustrations, pictures and drawings shown in the publication are typical of the subject matter they portray.

This catalog, when used in conjunction with the appropriate overhaul manual, shall be used for parts identification only. Under no circumstances shall this catalog be used as an assembly or installation document.

Any reference in this document to a suppliers/parts manufacturer's product, by name, trademark, part number or other description is solely for the purposes of identification and does not indicate or infer that Textron Lycoming accepts responsibility for quality control and/or airworthiness of parts which do not pass through the Textron Lycoming quality control system.

All Textron Lycoming publications will bear the copyright notice © Textron Lycoming 1986, "All Rights Reserved", and all Textron Lycoming publications are to be considered copyrighted and may not be reproduced without permission of the company.
--

SERVICE BULLETINS, INSTRUCTIONS AND LETTERS

Although the information contained in this parts catalog is up-to-date at time of publication, users are advised to procure current information through all Textron Lycoming distributors or from the factory by subscription. Consult the latest edition of Service Letter No. L114 for subscription information.

HOW TO ORDER PARTS

In ordering parts for your engine, observe the following instructions which will expedite shipment of correct parts required without delay.

- a. Always specify the model and serial number of your engine.
- b. Always specify part number, nomenclature and quantity required.

TABLE OF CONTENTS

SECTION	PAGE
Introduction	i
Table of Contents	ii
Oversize and Undersize Parts Listing	iii
1. CRANKCASE, CRANKSHAFT AND CAMSHAFT GROUP	
Crankcase Assembly	1-1
Oil Level Gage Assembly and Crankcase Related Parts	1-3
Crankshaft Assembly and Related Parts	1-5
Crankshaft Idler Gears, Tachometer Drive and Camshaft	1-7
Crankcase Attaching Parts	1-9
2. ACCESSORY HOUSING AND RELATED PARTS	
Accessory Housing Assembly	2-1
Oil Pump and Accessory Housing Attaching Parts	2-3
Propeller Governor Drive, Vacuum Pump Drive and Fuel Pump Covers	2-5
Oil Filter Assembly, Oil Cooler Bypass Valve and Breather Fitting	2-7
3. CYLINDER, PISTON AND VALVE TRAIN	
Connecting Rods, Pistons and Ring Assemblies	3-1
Cylinder Assembly	3-3
Cylinder Related Parts	3-5
Valve Assembly	3-7
Cylinder Head Drain Tubes, Intercylinder Cooling Baffles and Rocker Box Covers	3-9
4. IGNITION SYSTEM	
Magnetos, Magneto Drives, Harnesses and Spark Plugs	4-1
5. ELECTRICAL SYSTEM	
Starter - SUPPLIED BY AIRFRAME MANUFACTURER	5-1
Alternator Assembly and Belt	5-2
Alternator Mounting and Attaching Parts	5-3
6. OIL SUMP AND INDUCTION SYSTEM	
Oil Sump Assembly and Oil Suction Screen	6-1
Intake Pipes and Attaching Parts	6-3
Carburetor Assembly	6-5
7. SERVICE KIT SECTION	7-1
8. NUMERICAL INDEX	8-1

OVERSIZE AND UNDERSIZE PARTS LISTING

Part No.	Description	OVERSIZE									UNDERSIZE		
		P02 .002	P05 .005	P10 .010	P15 .015	P20 .020	P30 .030	P40 .040	P50 .050	M03 .003	M06 .006	M10 .010	
61681	GUIDE	See Latest Edition of Service Instruction No. 1256.											
66610	BUSHING		X	X									
66796	INSERT			X									
69796	DOWEL		X										
72057	SEAT		X	X		X	X						
72058	SEAT			X		X	X						
74230	GUIDE	See Latest Edition of Service Instruction No. 1256.											
74241	RING			X									
LW-11997	SEAL	See Latest Edition of Service Instruction No. 1324.											
LW-13521	BEARING			X						X*	X*	X*	
LW-13792	SEAL	See Latest Edition of Service Instruction No. 1324.											
LW-13884	BEARING				X					X*	X*	X*	
LW-16711	BEARING				X					X	X	X	
STD-1065	DOWEL	X	X	X	X								
01K22155-S	BUSHING		X	X	X	X							
01K22156-S	BUSHING		X	X	X	X							
14H21950	RING			X		X							
18A19441	BEARING				X					X	X	X	

* Also available in P10 oversize.

In addition to the above, studs are available in P03, P07 & P12.

NOTE

When ordering oversize and undersize parts, be sure to specify the required oversize and undersize dimension along with the proper part number. For example, to order bearing LW-13884 in .003 undersize, order part number LW-13884-M03. Oversize code letter is "P" while undersize code letter is "M". These letters are then followed by the number designating the size in thousandths of an inch.

SECTION

1

**CRANKCASE,
CRANKSHAFT AND
CAMSHAFT GROUP**

**CRANKCASE, CRANKSHAFT AND CAMSHAFT GROUP
CRANKCASE ASSEMBLY**

FIG REF. 1	PART NUMBER	DESCRIPTION	QTY. PER ASSY.
1	11B20061-3SL	CRANKCASE ASSEMBLY (See Note)	1
2	75154	STUD, 1/2-13 x 10-1/32 long	2
3	50-15	STUD, 1/2-13 x 1-7/8 long	8
4	38-13	STUD, 3/8-16 x 1-5/8 long	16
5	38D-17	STUD, 3/8-16 x 2-1/8 long, drilled	1
6	31C-12	STUD, 5/16-18 x 1-1/2 long	2
7	31C-13	STUD, 5/16-18 x 1-5/8 long	1
8	STD-557	DOWEL, 1/2 dia. x 11/16 long, hollow	2
9	STD-514	DOWEL, 5/16 dia. x 1/2 long	2
10	STD-1623	INSERT, 1/4-20 Helicoil x 3/8 long	2
11	LW-13793	STUD, 5/16-18 x 15/16 long, drilled	1
12	69796	DOWEL, Crankshaft bearing	2
13	1102	PLUG, 1/8-27 NPT, Allen head	6
14	STD-1339	PLUG, 1/16-27 NPT, Allen head	4
15	71032	BUSHING, Engine support	8
16	STD-619	WASHER, 17/32 I.D. x 1-3/4 O.D. x 5/32 thick	8

NOTE

This part is not available as a service item. Refer to Service Kits, Section 7, for applicable Crankcase Assembly and Governor Stud Kit Part Number.

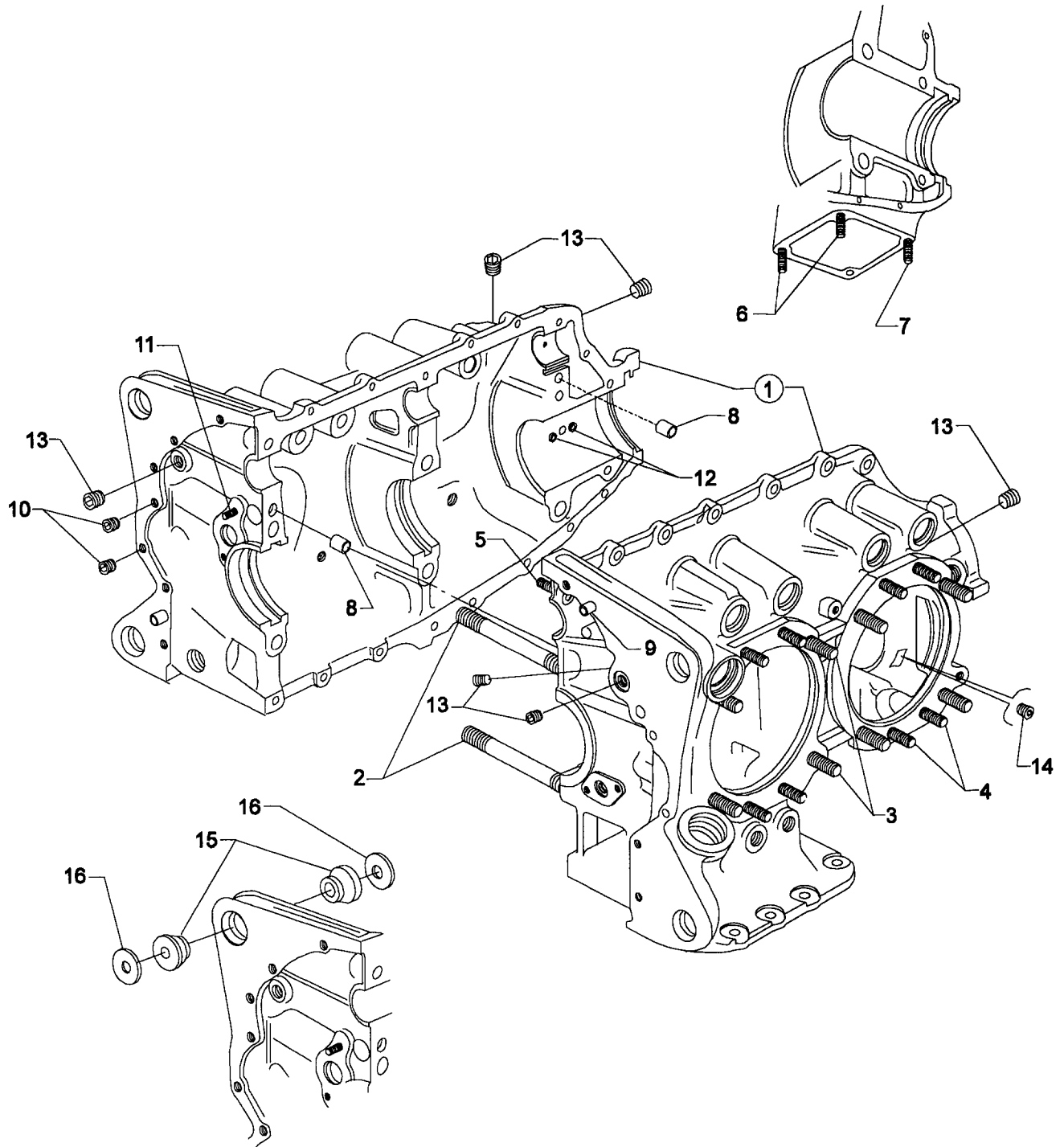

Figure 1. CRANKCASE ASSEMBLY

**CRANKCASE, CRANKSHAFT AND CAMSHAFT GROUP
OIL LEVEL GAGE ASSEMBLY AND CRANKCASE RELATED PARTS**

FIG. REF. 2	PART NUMBER	DESCRIPTION	QTY. PER ASSY.
1	LW-15970	TUBE, Oil level gage, short	1
2	72059	GASKET, Oil level gage	1
3	74068	RING, Oil level gage seal	1
4	LW-14793	GAGE ASSEMBLY, Oil level	1
5	1028-B	BALL, 11/16 diameter	1
6	61084*	SPRING, Oil pressure relief valve	1
	68668*	SPRING, Oil pressure relief valve	1
	77467*	SPRING, Oil pressure relief valve	1
	LW-11713*	SPRING, Oil pressure relief valve	1
	LW-18085*	SPRING, Oil pressure relief valve	1
7	06E19769-1.25	GASKET, 1-1/4 I.D. x 1-1/2 O.D. x 3/32 annular	1
8	77808	VALVE ASSY., Oil pressure relief valve, adj.	1
9	LW-16711	BEARING, Crankshaft	4
10	LW-13884	BEARING, Crankshaft, front	2
	18A19441	BEARING, Crankshaft, front (alternate)	2
11	LW-13792**	SEAL, Crankshaft oil, solid	1
	LW-11997**	SEAL, Crankshaft oil, split	1
12	72075	SEAL, Oil, 3/32 section x 7/16 I.D.	2
13	72091	RING, Oil seal, 23/64 I.D. x 7/64 dia.	2
14	72877	BODY, Hydraulic tappet	8

* Select spring to give a minimum of three threads exposed on adjusting screw to allow field adjustment. Reference latest revision of Textron Lycoming Table of Limits SSP-1776, Part I for spring identification.

** See latest edition of Textron Lycoming Service Instruction No. 1324 for installation.

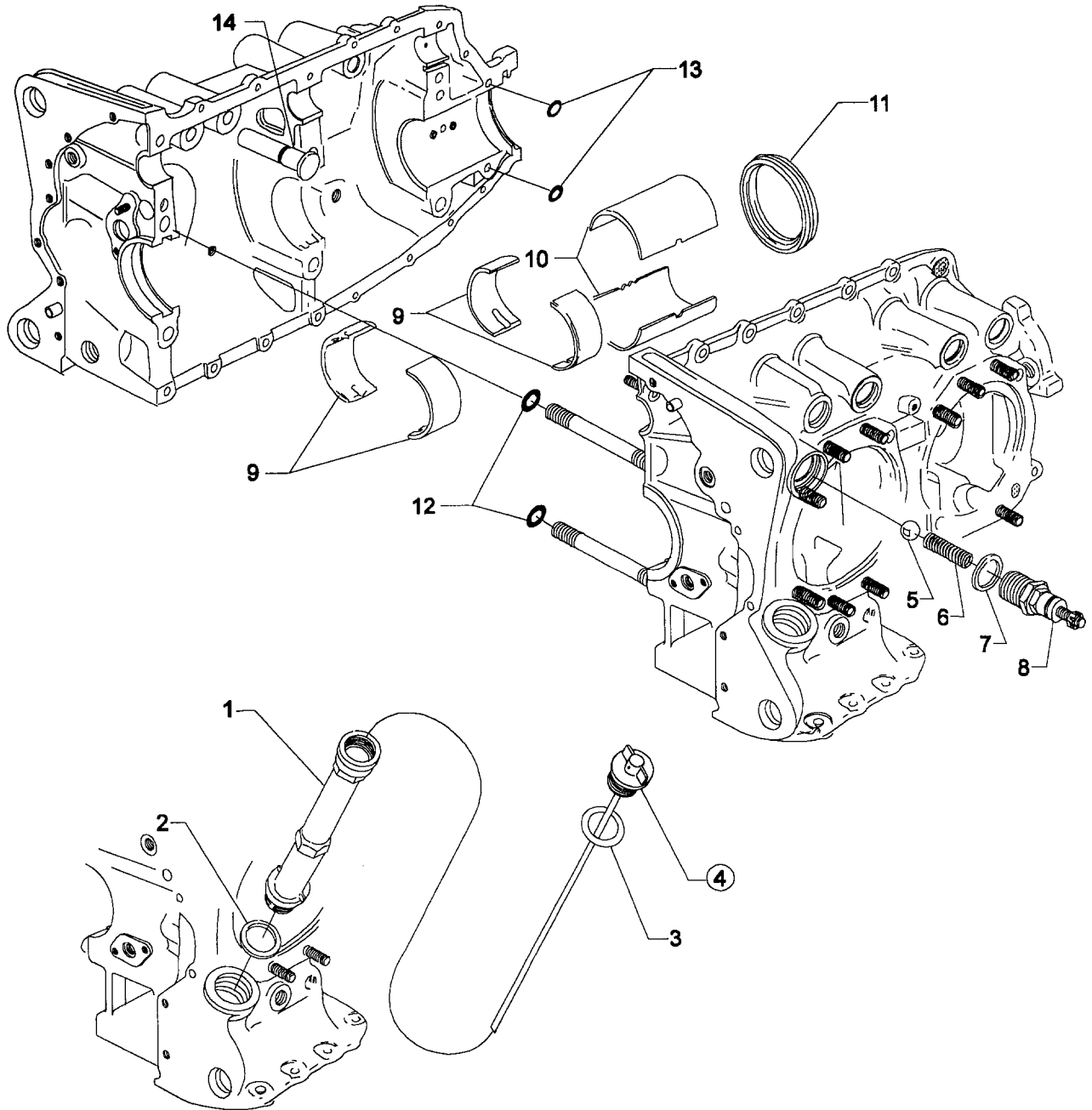

Figure 2. OIL LEVEL GAGE ASSEMBLY AND CRANKCASE RELATED PARTS

**CRANKCASE, CRANKSHAFT AND CAMSHAFT GROUP
CRANKSHAFT ASSEMBLY AND RELATED PARTS**

FIG. REF. 3	PART NUMBER	DESCRIPTION	QTY. PER ASSY.
1	13B27143	CRANKSHAFT AND BUSHING ASSEMBLY	1
2	STD-1065	DOWEL, Stepped, 5/16 & 1/4 dia. x 35/64 long	1
3	STD-1211	PLUG, 2.00 dia. expansion	1
4	01K22156-S	BUSHING, Propeller flange	1
5	01K22155-S	BUSHING, Propeller flange	5
6	13S19646*	GEAR, Crankshaft	1
7	LW-18639	LOCKPLATE, Crankshaft gear	1
8	STD-2213	SCREW, 5/16-24 x 1.00 long	1
9	31M22194	SUPPORT ASSY., Starter ring gear, 12/14 pitch	1
10	72566	GEAR, Starter ring	1

* See latest edition of Textron Lycoming Service Bulletin No. 475 for proper installation.

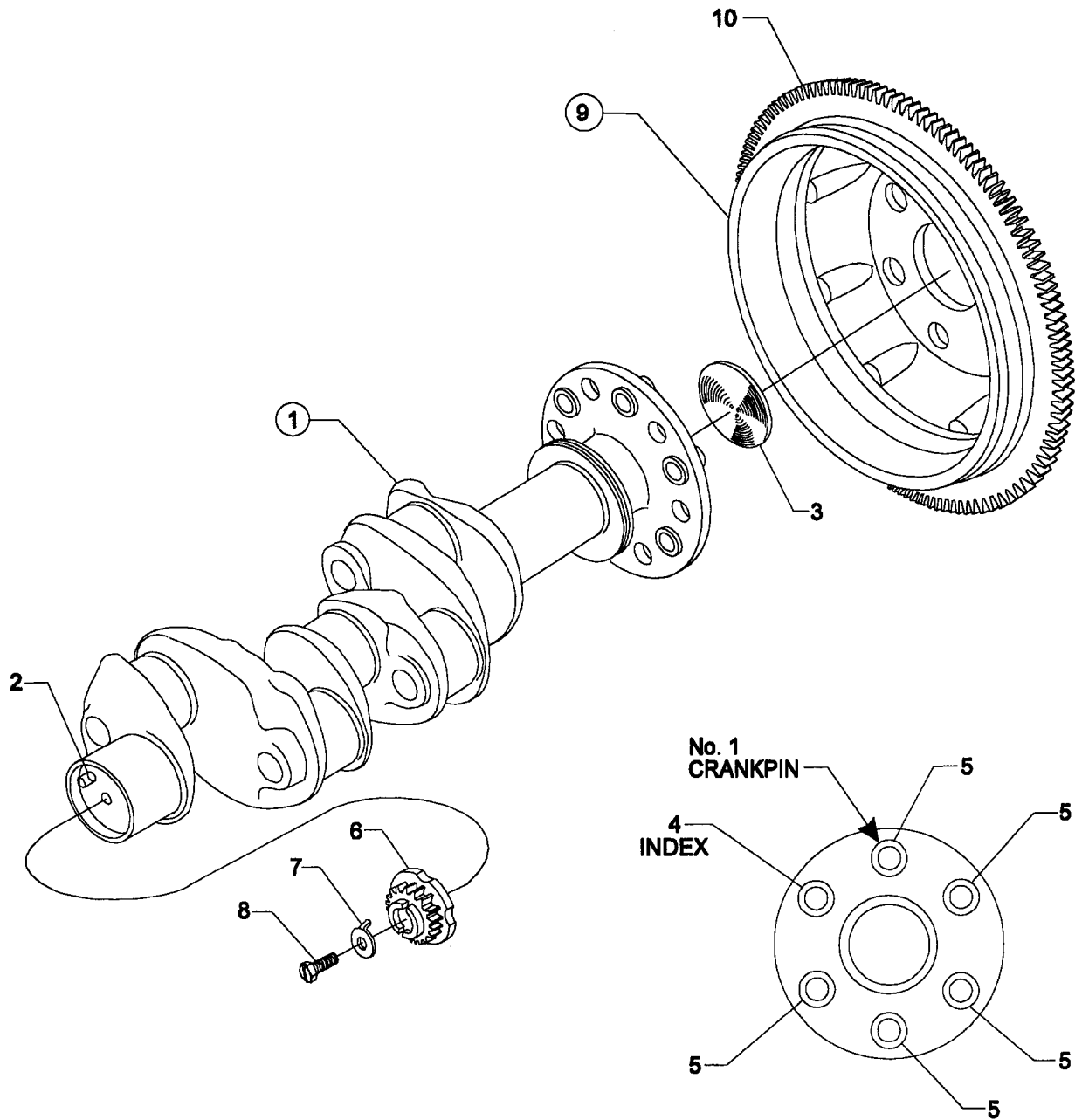

Figure 3. CRANKSHAFT ASSEMBLY AND RELATED PARTS

**CRANKCASE, CRANKSHAFT AND CAMSHAFT GROUP
CRANKSHAFT IDLER GEARS, TACHOMETER DRIVE AND CAMSHAFT**

FIG. REF. 4	PART NUMBER	DESCRIPTION	QTY. PER ASSY.
1	74996	GEAR ASSY., Crankshaft idler, plain	2
2	77309	BUSHING, Crankshaft idler gear	2
3	76121	SHAFT ASSY., Tachometer	1
4	LW-18667	PIN, 3/16 dia. x 2-21/64 long	1
5	STD-2231	RING, Internal retaining	1
6	LW-13796	SHAFT, Crankshaft idler gear	2
7	LW-31H0.88	BOLT, 5/16-18 x 7/8 long, hex. hd., dr.	3
8	STD-2168	NUT, 5/16-18 NC-3 slotted shear	1
9	LW-18840	CAMSHAFT ASSEMBLY	1
10	76118	SPACER, Tach. shaft centering	1

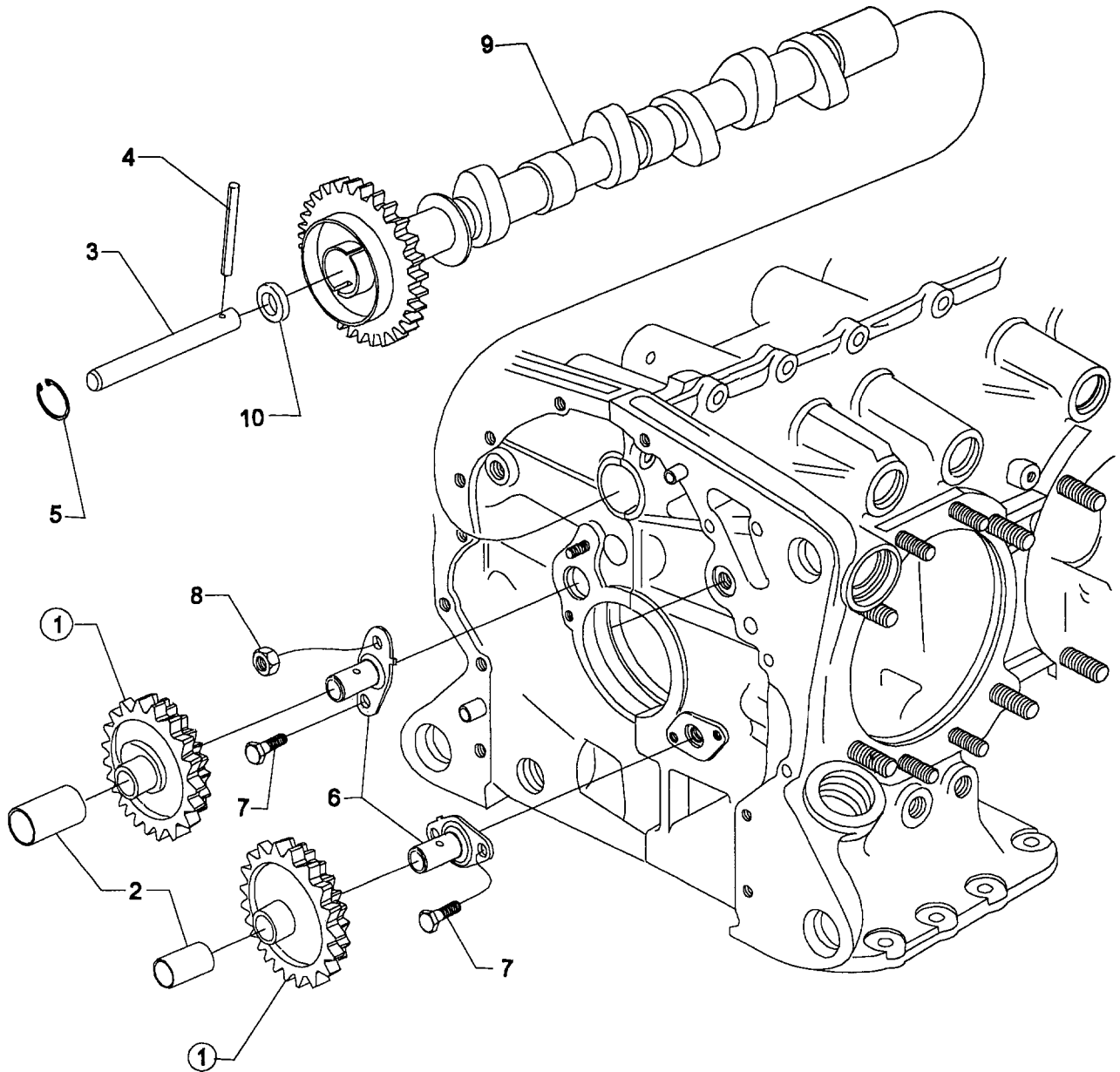

Figure 4. CRANKSHAFT IDLER GEARS, TACHOMETER DRIVE AND CAMSHAFT

**CRANKCASE, CRANKSHAFT AND CAMSHAFT GROUP
CRANKCASE ATTACHING PARTS**

FIG. REF. 5	PART NUMBER	DESCRIPTION	QTY. PER ASSY.
1	LW-25-1.50	BOLT, 1/4-20 x 1-1/2 long, hex. hd.	8
2	STD-8	WASHER, 1/4 plain	19
3	60803	STRAP, Lifting	1
4	LW-25-1.75	BOLT, 1/4-20 x 1-3/4 long, hex. hd.	1
5	LW-25-1.13	BOLT, 1/4-20 x 1-1/8 long, hex. hd.	3
6	STD-160	WASHER, 1/4 lock, internal teeth	12
7	STD-1411	NUT, 1/4-20 plain	9
8	LW-25S1.50	BOLT, 1/4-20 x 1-1/2 long, hex. hd., dr. end	3
9	STD-8	WASHER, 1/4 plain (Max. 9)	AR
10	STD-1409	NUT, 1/4-20 slotted shear	3
11	STD-33	WASHER, 3/8 plain, 1/16 thick	3
12	AN960-616L	WASHER, 3/8 plain, 1/32 thick	1
13	STD-872	NUT, 3/8-24 slotted	1
14	AN6-34A	BOLT, 3/8-24 x 3-37/64 long, hex. hd.	2
15	STD-33	WASHER, 3/8 plain	2
16	STD-678	WASHER, 3/8 lock, internal teeth	2
17	STD-596	NUT, 3/8-24 plain	2
18	76220	STUD, 1/2-20 x 10-45/64 long	4

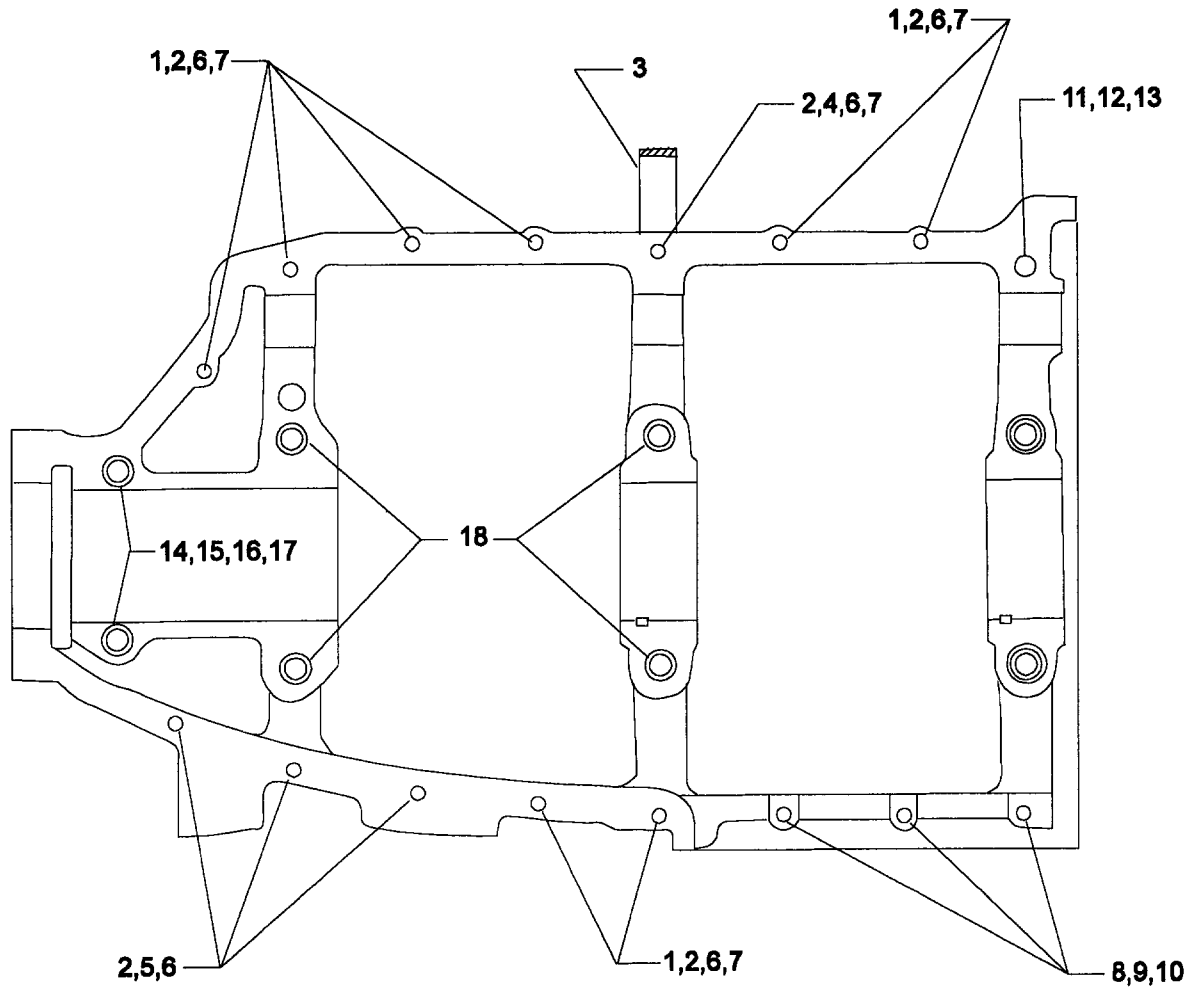

Figure 5. CRANKCASE ATTACHING PARTS

SECTION

2

**ACCESSORY
HOUSING AND
RELATED PARTS**

**ACCESSORY HOUSING AND RELATED PARTS
ACCESSORY HOUSING ASSEMBLY**

FIG. REF. 6	PART NUMBER	DESCRIPTION	QTY. PER ASSY.
1	73818	GASKET, Accessory housing	1
2	21A21533-03	HOUSING ASSY., Accessory	1
3	61400	STUD, 1/4-20 x 1-3/16 long	4
4	31C-12	STUD, 5/16-18 x 1-1/2 long	8
5	31CD-17	STUD, 5/16-18 x 2-1/8 long, drilled	3
6	1102	PLUG, 1/8-27 NPT, Allen head	4
7	STD-784	PLUG, 3/8-18 NPT, Allen head	1

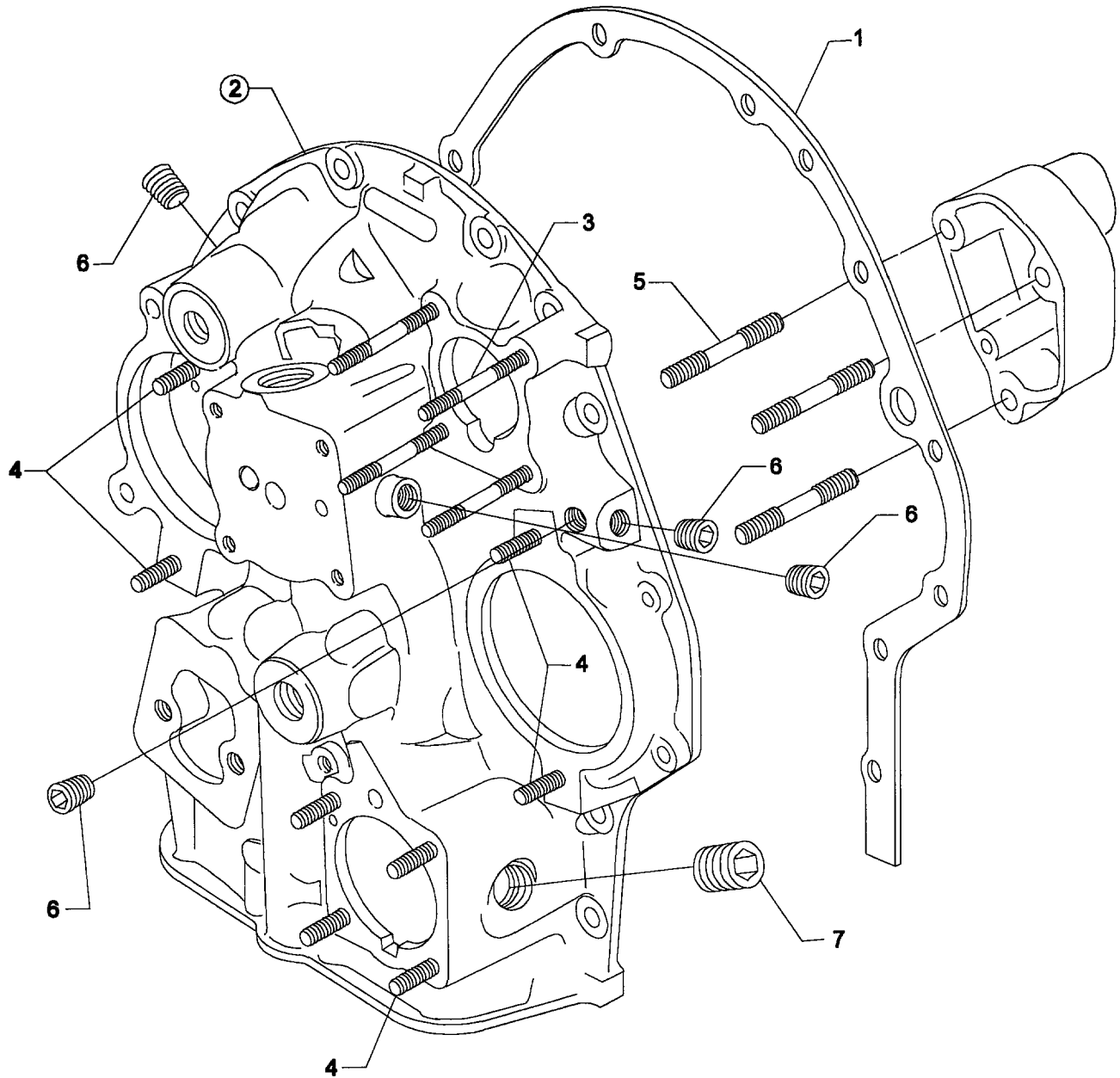

Figure 6. ACCESSORY HOUSING ASSEMBLY

**ACCESSORY HOUSING AND RELATED PARTS
OIL PUMP AND ACCESSORY HOUSING ATTACHING PARTS**

FIG. REF. 7	PART NUMBER	DESCRIPTION	QTY. PER ASSY.
1	78531	BODY, Oil pump	1
2	05K19423-S*	OIL PUMP IMPELLER KIT	1
3	61174	SHAFT, Oil pump drive	1
4	STD-35	WASHER, 5/16 plain	3
5	STD-1420	NUT, 5/16-18 slotted	3
6	LW-14260	SEAL, Tachometer drive, oil	1
7	STD-8	WASHER, 1/4 plain	12
8	STD-160	WASHER, 1/4 lock, internal teeth	12
9	LW-25-0.94	BOLT, 1/4-20 x 15/16 long, hex. hd.	9
10	LW-25-1.13	BOLT, 1/4-20 x 1-1/8 long, hex. hd.	1
11	LW-25-1.50	BOLT, 1/4-20 x 1-1/2 long, hex. hd.	2

* See latest edition of Textron Lycoming Service Bulletin No. 524.

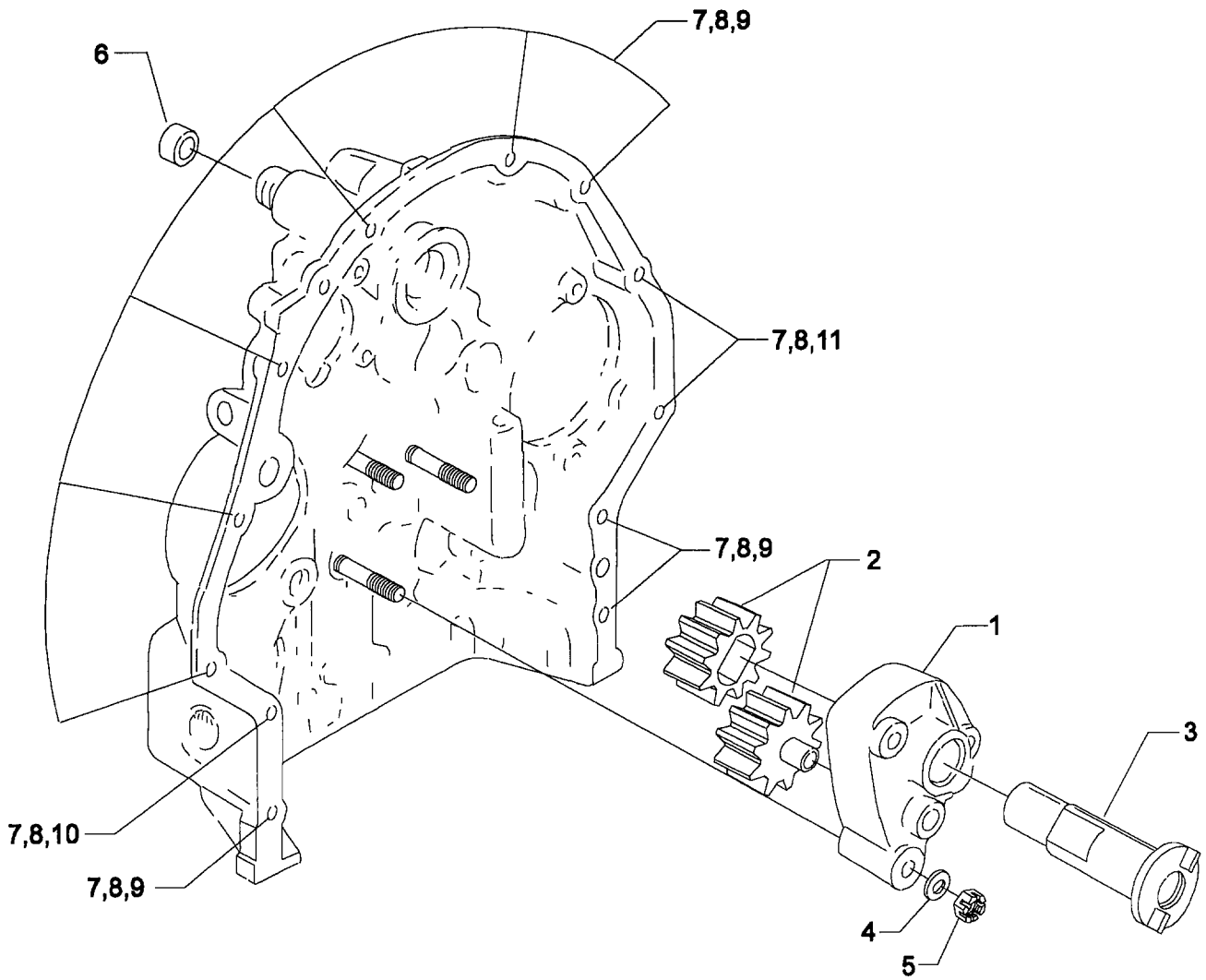

Figure 7. OIL PUMP AND ACCESSORY HOUSING ATTACHING PARTS

**ACCESSORY HOUSING AND RELATED PARTS
PROPELLER GOVERNOR DRIVE, VACUUM PUMP DRIVE AND FUEL PUMP COVERS**

FIG. REF. 8	PART NUMBER	DESCRIPTION	QTY. PER ASSY.
1	69551	GASKET, Accessory drive adapter	1
2	69106	COVER, Governor drive adapter pad	1
3	STD-35	WASHER, 5/16 plain	4
4	STD-475	WASHER, 5/16 lock, internal teeth	4
5	STD-1410	NUT, 5/16-18 plain	4
6	STD-783*	PLUG, 1/4-18 NPT, Allen head	1
7	61183	GASKET, Vacuum pump	1
8	60430	COVER, Vacuum pump	1
9	STD-8	WASHER, 1/4 plain	4
10	STD-160	WASHER, 1/4 lock, internal teeth	4
11	STD-1411	NUT, 1/4-20 plain	4
12	60096	GASKET, Fuel pump	1
13	65098	COVER, Fuel pump	1
14	STD-33	WASHER, 3/8 plain	2
15	LW-38-0.75	BOLT, 3/8-16 x 3/4 long	2
16	STD-678	WASHER, 3/8 lock, internal teeth	2

* Used when no propeller governor oil line is installed.

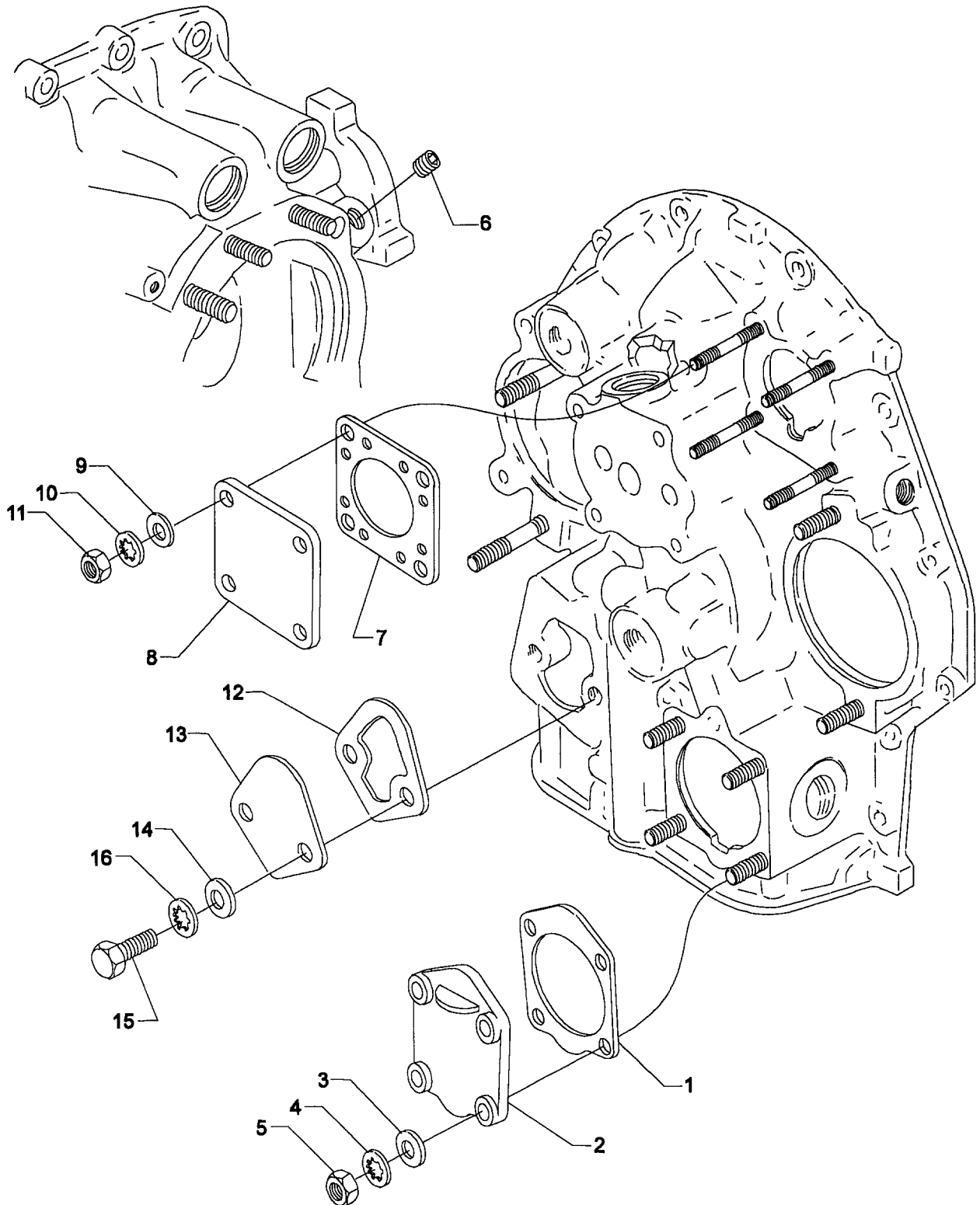

Figure 8. PROPELLER GOVERNOR DRIVE, VACUUM PUMP DRIVE AND FUEL PUMP COVERS

ACCESSORY HOUSING AND RELATED PARTS
OIL FILTER ASSEMBLY, OIL COOLER BYPASS VALVE AND BREATHER FITTINGS

FIG. REF. 9	PART NUMBER	DESCRIPTION	QTY. PER ASSY.
1	62817	SCREEN ASSY., Oil pressure	1
2	61173	GASKET, Oil pressure housing	1
3	69510	HOUSING, Oil pressure screen	1
4	06E19769-0.63	GASKET, 7/8 O.D. x 5/8 I.D. x 3/32 annular	1
5	STD-8	WASHER, 1/4 plain	4
6	STD-1856	SCREW, 1/4-20 x 1.00 long, hex. hd.	4
7	53E22144	VALVE ASSY., Temp. control oil cooler bypass	1
8	76510	GASKET, Valve assembly	1
9	06E19769-0.63	GASKET, 7/8 O.D. x 5/8 I.D. x 3/32 annular	1
10	62417	PLUG, Oil cooler bypass	1
11	STD-784	PLUG, 3/8-18 NPT, Allen head	2
12	71140	FITTING, Breather	1

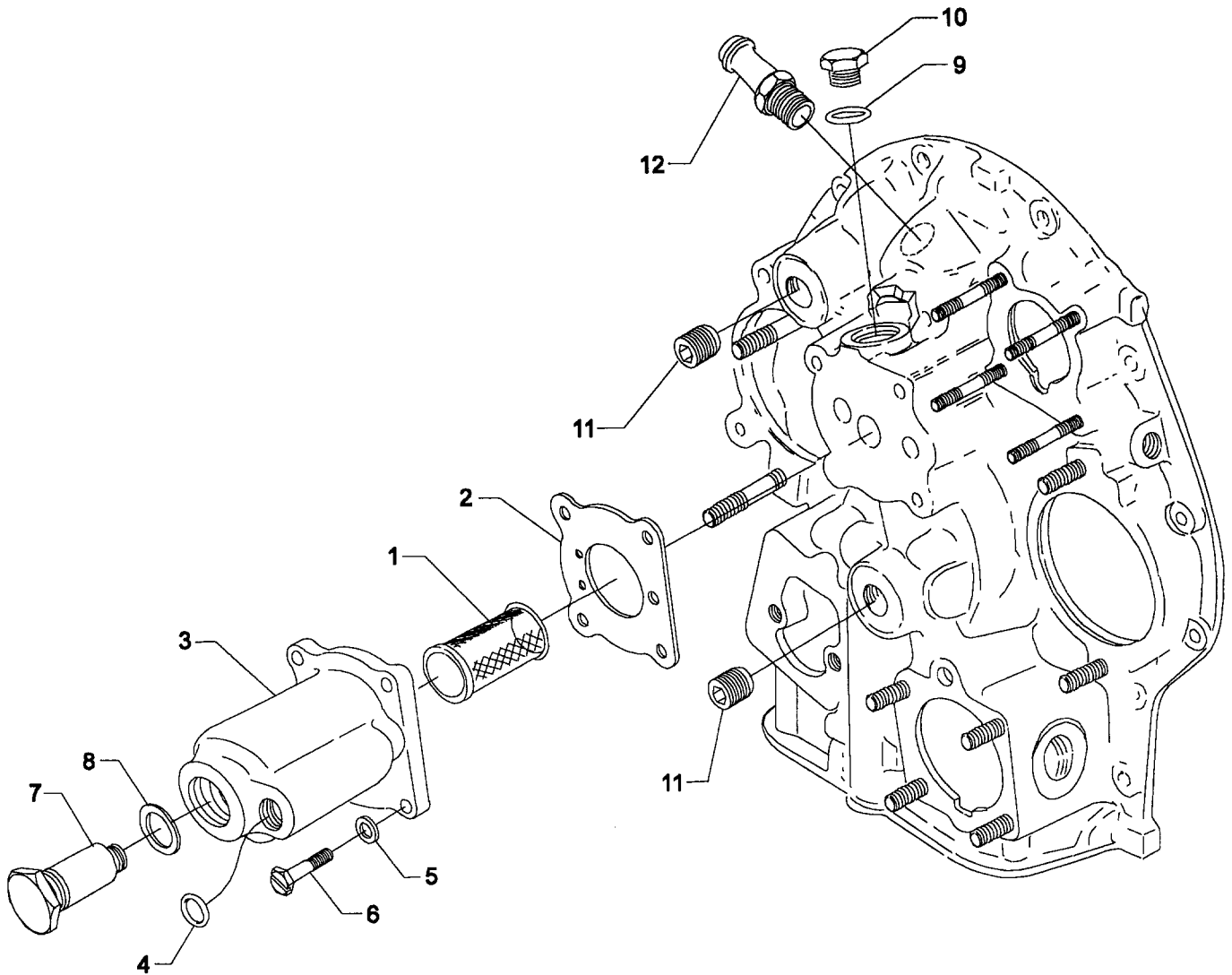

Figure 9. OIL FILTER ASSEMBLY, OIL COOLER BYPASS VALVE AND BREATHER FITTINGS

SECTION

3

**CYLINDER, PISTON
AND VALVE TRAIN**

**CYLINDER, PISTON AND VALVE TRAIN
CONNECTING RODS, PISTONS AND RING ASSEMBLIES**

FIG. REF. 10	PART NUMBER	DESCRIPTION	QTY. PER ASSY.
1	LW-11750-S	CONNECTING ROD ASSEMBLY	4
2	LW-13923	BUSHING, Connecting rod, upper	4
3	75061	BOLT, Connecting rod	8
4	LW-12186	NUT, Connecting rod bolt	8
5	LW-13521	BEARING, Connecting rod	8
6	75089	PISTON, Compression ratio, 8.50:1	4
7	LW-14077*	PIN, Piston	4
8	LW-11775*	PLUG, Piston pin (piloted)	8
9	74241	RING, Piston compression	8
10	14H21950	RING, Piston, oil regulating, expander type	4

* See latest edition of Textron Lycoming Service Instruction No. 1267.

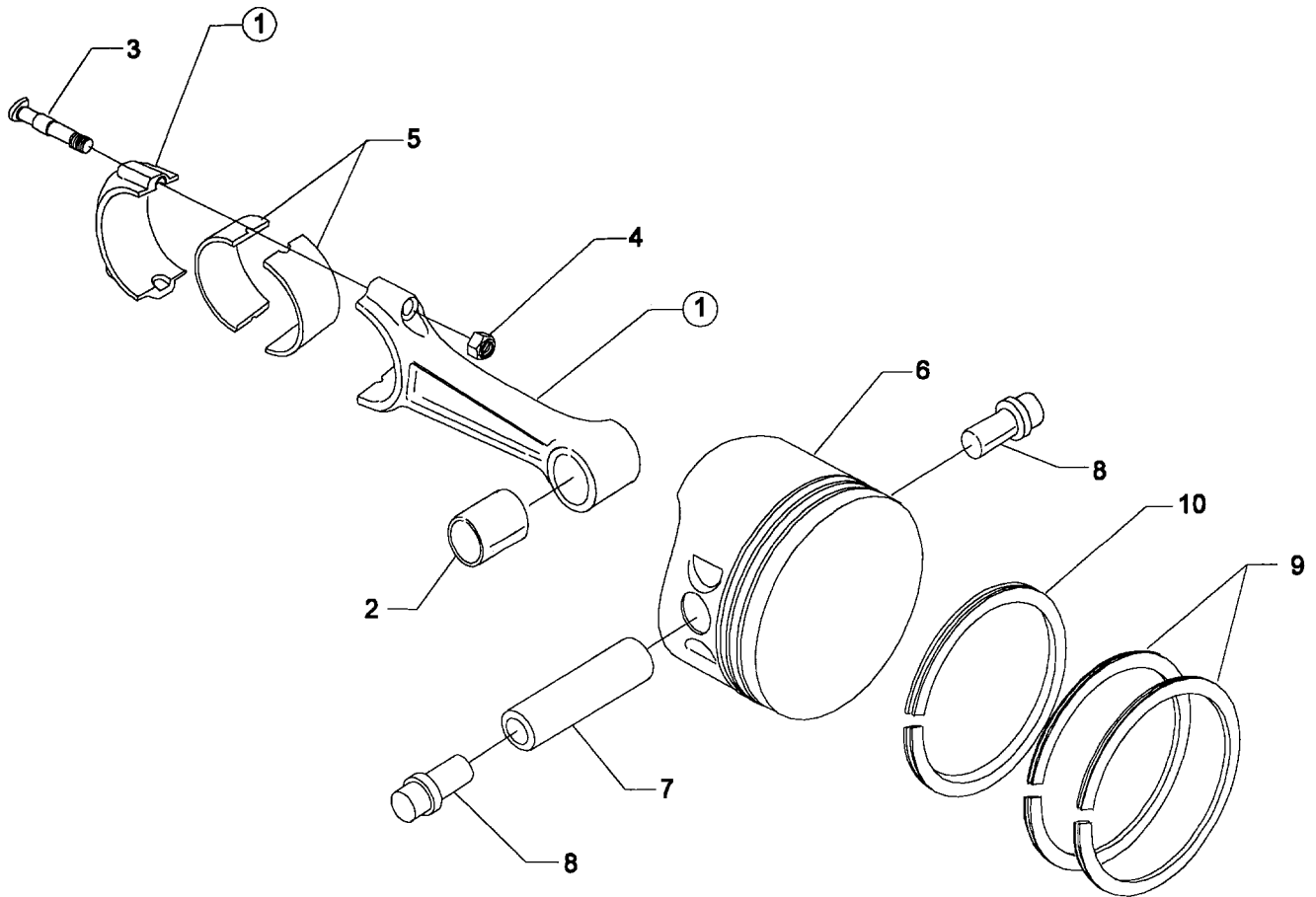

Figure 10. CONNECTING RODS, PISTONS AND RING ASSEMBLIES

**CYLINDER, PISTON AND VALVE TRAIN
CYLINDER ASSEMBLY**

FIG. REF. 11	PART NUMBER	DESCRIPTION	QTY. PER ASSY.
1	LW-13870	CYLINDER & HEAD ASSY., Nitrided	4
2	72057	SEAT, Intake valve	4
3	72058	SEAT, Exhaust valve	4
4	61681*	GUIDE, Valve, intake, flanged	4
5	74230*	GUIDE, Valve, exhaust, flanged	4
6	66796	INSERT, Spark plug, 18 - 1.5 MM	8
7	STD-1353	INSERT, No. 10-24 Heli-coil x 3/8 long	4
8	31C-12	STUD, 5/16-18 x 1-1/2 long	8
9	25C-8	STUD, 1/4-20 x 1.00 long	4
10	MS20823-6D	ELBOW, 45°, 3/8 flared tube	4
11	66610	BUSHING, Rocker shaft	16
12	1102	PLUG, 1/8-27 NPT, Allen head	4
13	77611	GASKET, Exhaust flange	4
14	STD-35	WASHER, 5/16 plain	8
15	STD-475	WASHER, 5/16 lock, internal teeth	8
16	STD-1410	NUT, 5/16-18 plain	8
17	1102**	PLUG, 1/8-27 NPT, Allen head	4

* See latest edition of Textron Lycoming Service Instruction No. 1256.

** Additional plugs used when no priming lines are installed.

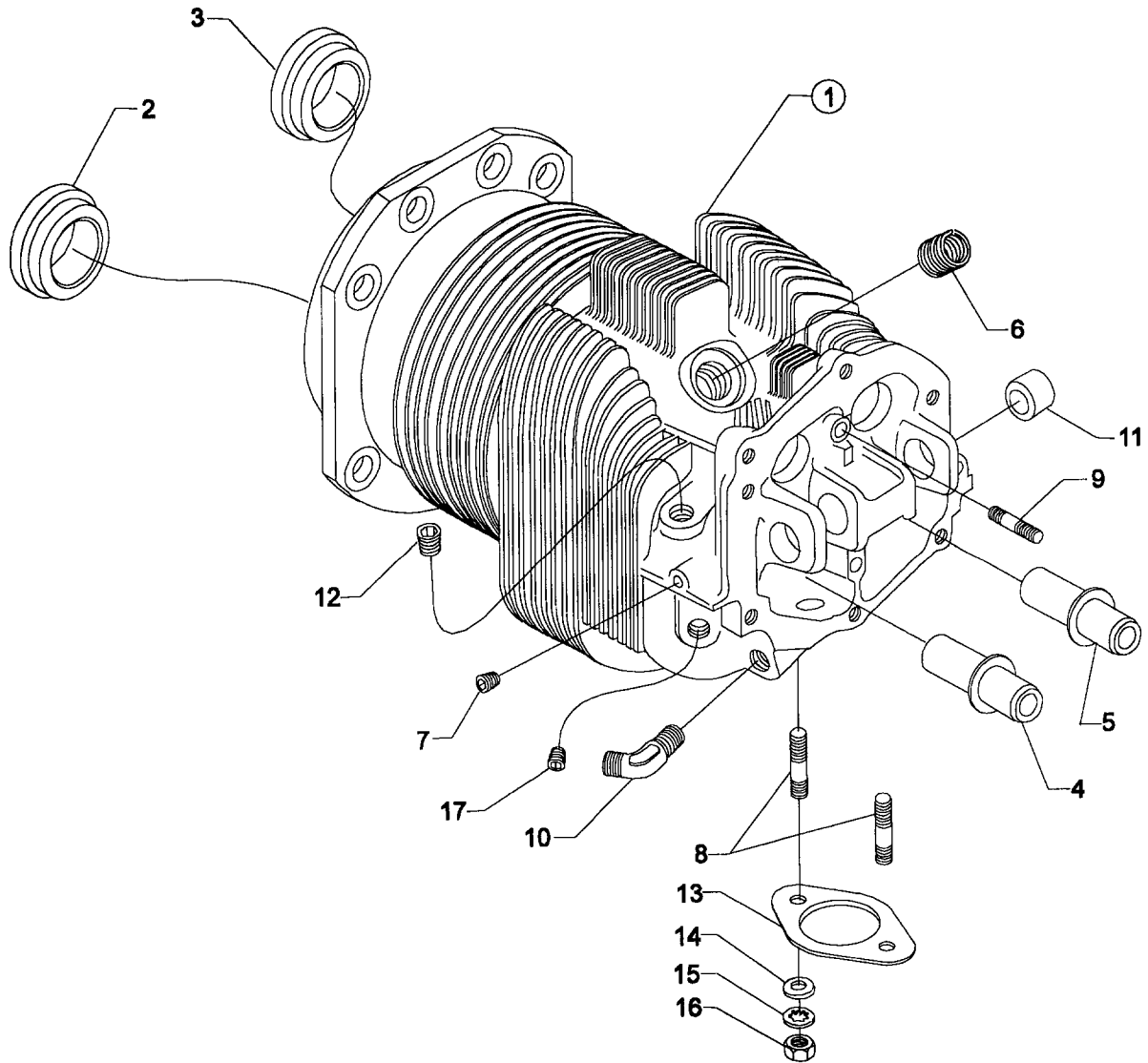

Figure 11. CYLINDER ASSEMBLY

**CYLINDER, PISTON AND VALVE TRAIN
CYLINDER RELATED PARTS**

FIG. REF. 12	PART NUMBER	DESCRIPTION	QTY. PER ASSY.
1	15F19957-34*	ROD ASSY., Push (A total of 8 required)	AR
	15F19957-35*	ROD ASSY., Push (A total of 8 required)	AR
	15F19957-36*	ROD ASSY., Push (A total of 8 required)	AR
	73437*	ROD ASSY., Push (A total of 8 required)	AR
2	17F19357**	ROCKER ASSY., Valve	8
3	74637	BUSHING, Valve rocker	8
4	LW-13790	SHAFT, Valve rocker	4
5	LW-12892	THRUST BUTTON, Rocker shaft	8
6	71481	RING, Oil seal, 3/32 dia. x 4-27/32 long	4
7	74887	SPACER, 33/64 I.D. x 7/8 O.D. x 3/8 thick	2
8	383-B	NUT, 3/8-24 plain	16
9	STD-2090	NUT, 1/2 -20 plain	18

* See latest edition of Textron Lycoming Service Instruction No. 1060 for complete push rod application.

** Due to the size of the area where the part number is stamped, the last five digits may be all that is shown (19357).

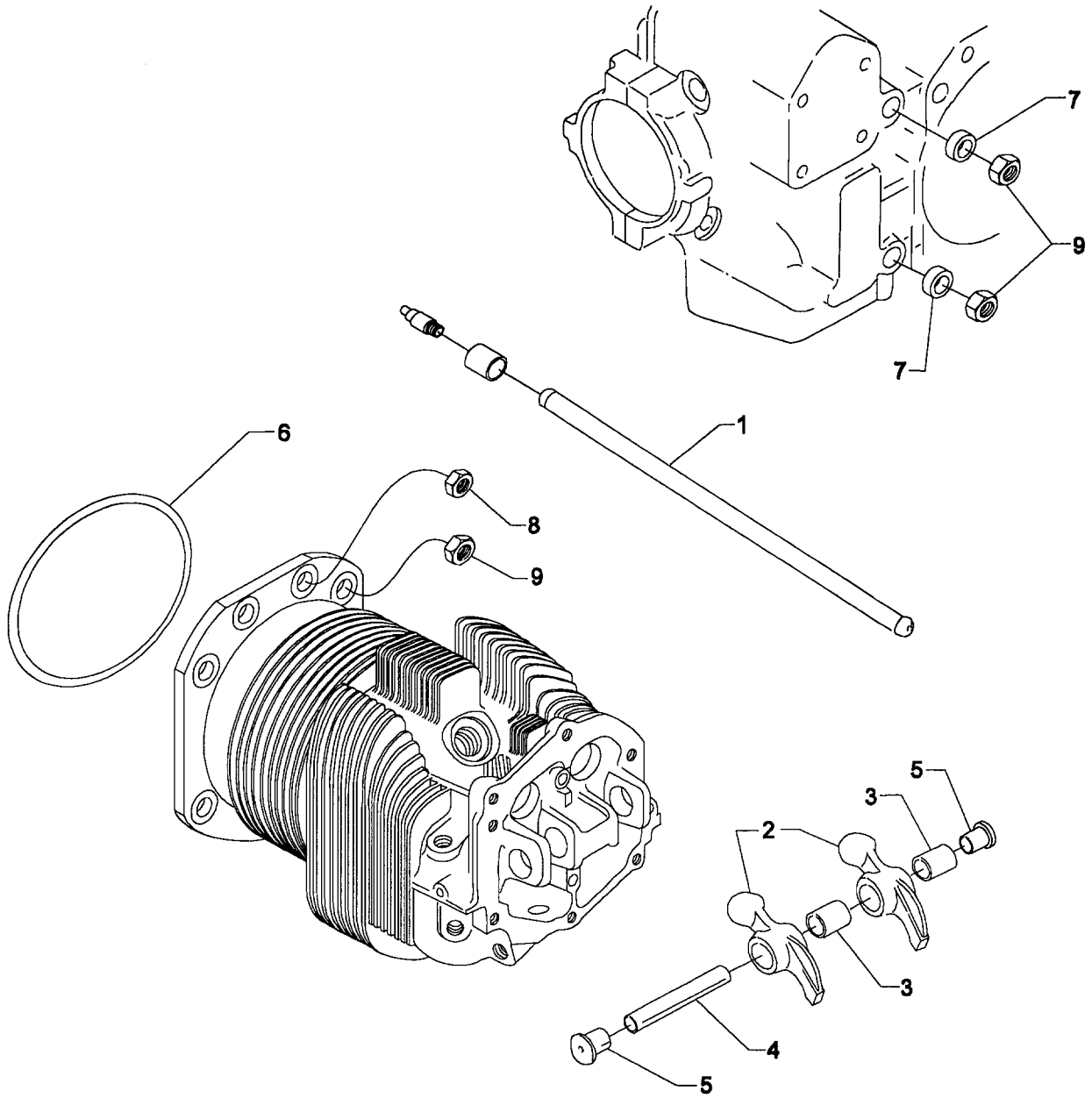

Figure 12. CYLINDER RELATED PARTS

**CYLINDER, PISTON AND VALVE TRAIN
VALVE ASSEMBLY**

FIG. REF. 13	PART NUMBER	DESCRIPTION	QTY. PER ASSY.
1	73938	VALVE, Intake	4
2	LW-19001	VALVE, Exhaust (rotator type)	4
3	LW-11795	SPRING, Valve, inner	8
4	LW-11800	SPRING, Valve, outer	8
5	65441	SEAT, Valve spring, lower intake	4
6	LW-13323	SEAT, Valve spring, lower exhaust	4
7	LW-10077	SEAT, Valve spring, upper intake	4
8	LW-16475	SEAT, Valve spring, upper exhaust (rotator type)	4
9	60009	KEY, Valve, intake	8
10	17C21191	KEY, Valve, exhaust (rotator type)	8
11	17C19386	CAP, Valve stem, exhaust (rotator type)	4
12	78290	PLUNGER ASSY., Hydraulic tappet	8
13	15B21319	SOCKET, Hydraulic tappet	8
14	LW-11485	SHROUD TUBE ASSY., Push rod	8
15	LW-14995	SPRING, Shroud tube	4
16	LW-12272	LOCKPLATE, Shroud tube	4
17	STD-1411	NUT, 1/4-20 plain	4
18	LW-18661	SEAL, Shroud tube	8
19	70310	SEAL, Shroud tube	8

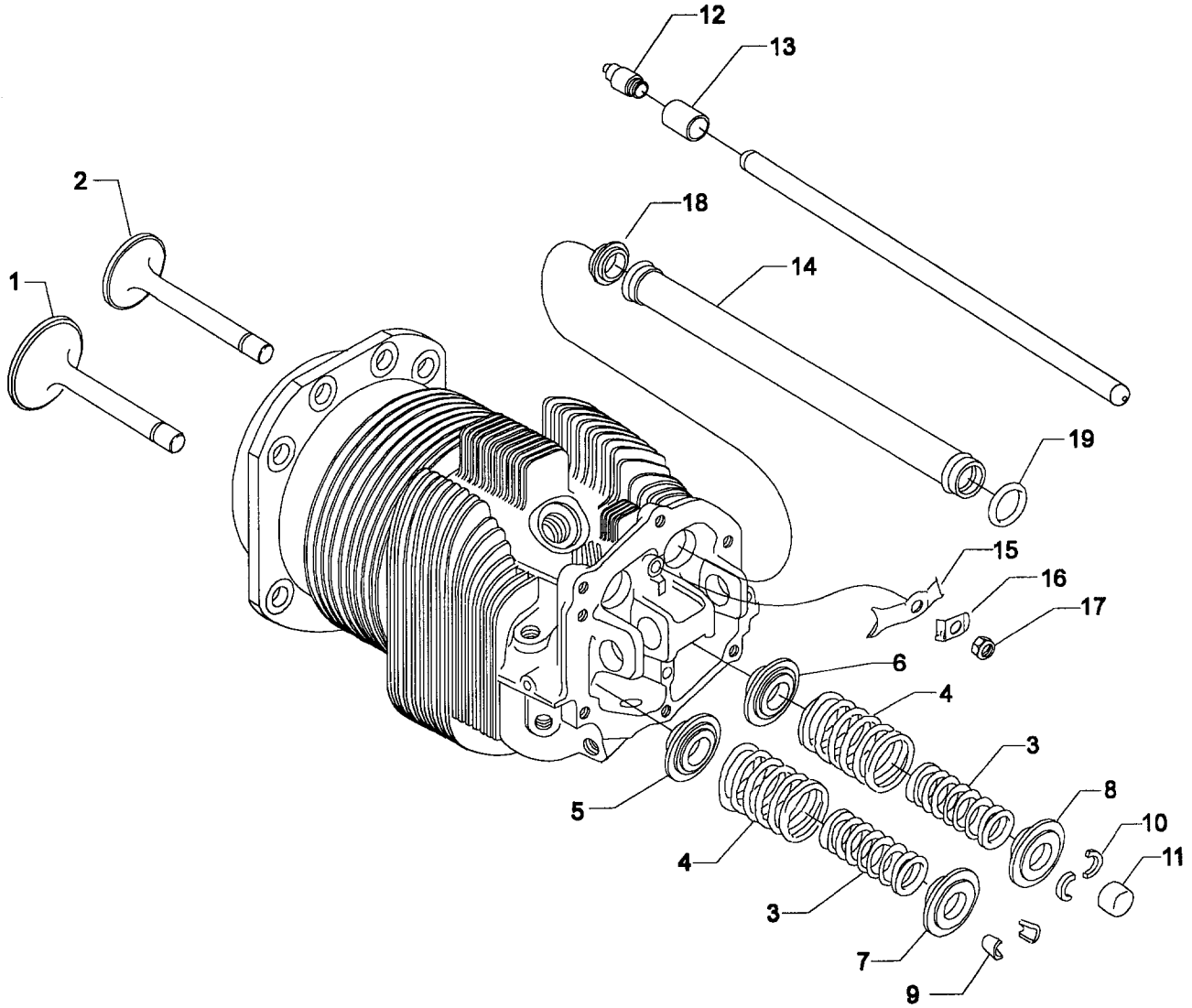

Figure 13. VALVE ASSEMBLY

**CYLINDER, PISTON AND VALVE TRAIN
CYLINDER HEAD DRAIN TUBES, INTERCYLINDER COOLING BAFFLES
AND ROCKER BOX COVERS**

FIG. REF. 14	PART NUMBER	DESCRIPTION	QTY. PER ASSY.
1	STD-684	NIPPLE, Straight, 3/8 I.D. hose	4
2	STD-1821	HOSE, 3/8 x 2-1/2 long	4
3	LW-15592-5-05	CLAMP, Hose	8
4	68759	TUBE ASSY., Cyl. head oil drain, cyl. no. 1	1
5	68760	TUBE ASSY., Cyl. head oil drain, cyl. no. 2	1
6	68761	TUBE ASSY., Cyl. head oil drain, cyls. no. 3 & 4	2
7	LW-15839	BAFFLE ASSY., Intercylinder	2
8	71611	RETAINER, Intercylinder baffle	2
9	71629	HOOK, Intercylinder baffle retainer	2
10	75906	GASKET, Rocker box cover	4
11	61247	COVER, Rocker box	4
12	STD-1925	SCREW, 1/4-20 x 5/8 long, pan. hd., self-locking	24

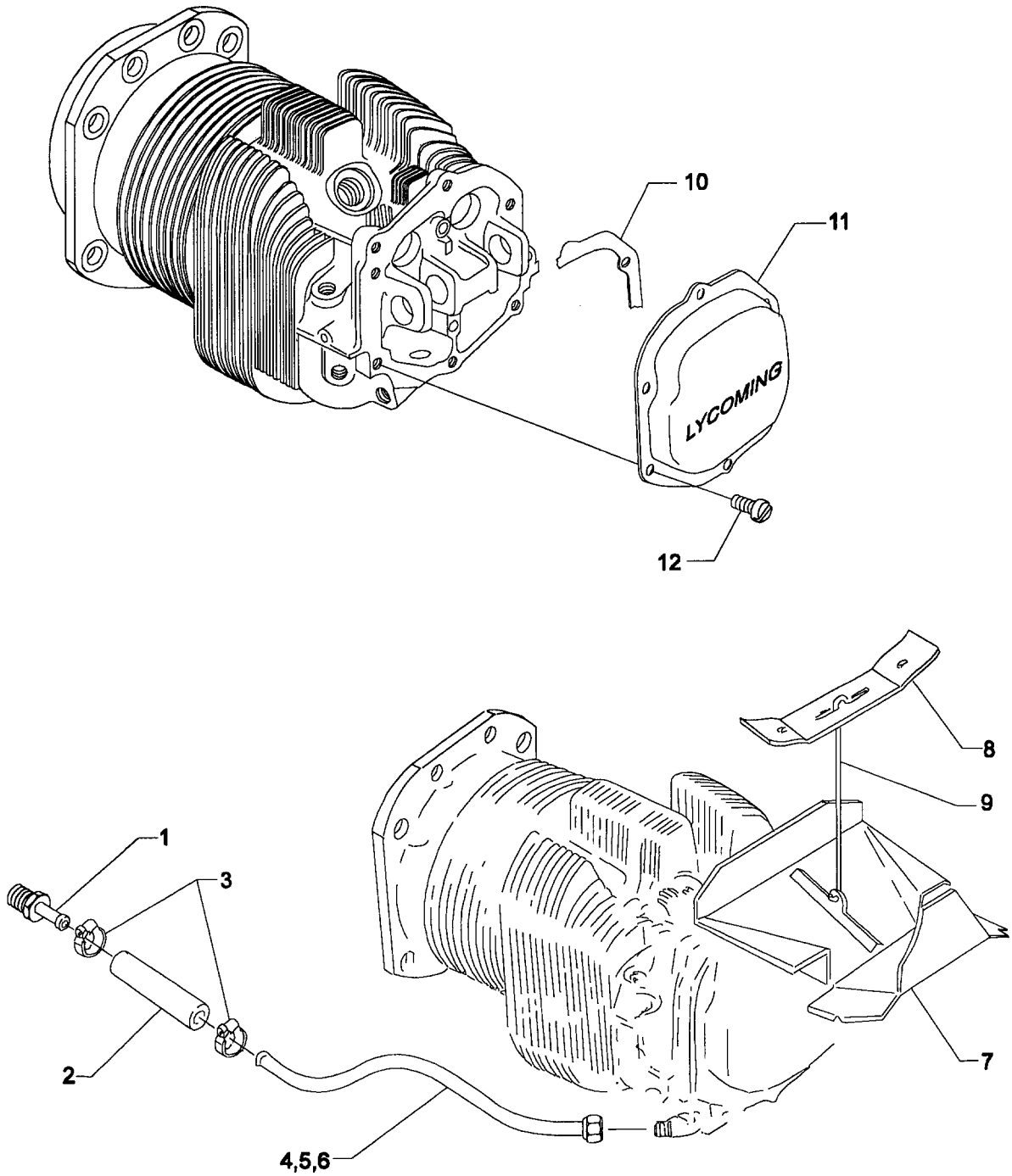

Figure 14. CYLINDER HEAD DRAIN TUBES, INTERCYLINDER COOLING BAFFLES AND ROCKER BOX COVERS

SECTION

4

IGNITION SYSTEM

IGNITION SYSTEM**MAGNETOS, MAGNETO DRIVES, HARNESSES AND SPARK PLUGS**

FIG. REF. 15	PART NUMBER	DESCRIPTION	QTY. PER ASSY.
1	68C19622	GEAR, Magneto	2
2	62224	GASKET, Magneto adapter	2
3	66B21772	MAGNETO, S4LSC-200, retard	1
	66B21779+	MAGNETO, S4LSC-204T	1
4	STD-1727	WASHER, Plain, 3/4 O.D. x 11/32 I.D. x 1/8 thick	4
5	STD-475	WASHER, 5/26 lock, internal teeth	4
6	STD-1410	NUT, 5/16-18 plain	4
7	LW-M-2403	HARNESS ASSY., Left Magneto	1
	LW-M-2404	HARNESS ASSY., Right Magneto	1
8	LW-M-2375	PLATE, Spark plug	2
9	72351	SCREW, No. 10-32 self-locking	8
10	LW-14060	CLIP, Two wire	2
11	STD-8	WASHER, 1/4 plain	2
12	STD-160	WASHER, 1/4 lock, internal teeth	1
13	STD-1916	SCREW, 1/4-20 x 1-1/8 long	1
14	LW-25-1.25	BOLT, 1/4-20 x 1-1/4 long	1
15	STD-1411	NUT, 1/4-20 plain	2
16	LW-18959-175-25	CLAMP, 1-3/4 I.D. with 1/4 dia.	4
17	STD-553	SCREW, No. 6-32 x 1/2 long	4
18	AN365-632A	NUT, No. 6-32 self-locking	4
19	76734	ZIP STRAP	2
20	1182-E7*	SPARK PLUG, Champion (REM38E) or Auburn (SR8)	8

* Item No. 20 spark plugs are used in current production only. Additional spark plugs are available for this engine. See latest edition of Textron Lycoming Service Instruction No. 1042 for complete listing of all approved spark plugs.

+ Magneto with electric tachometer pickup.

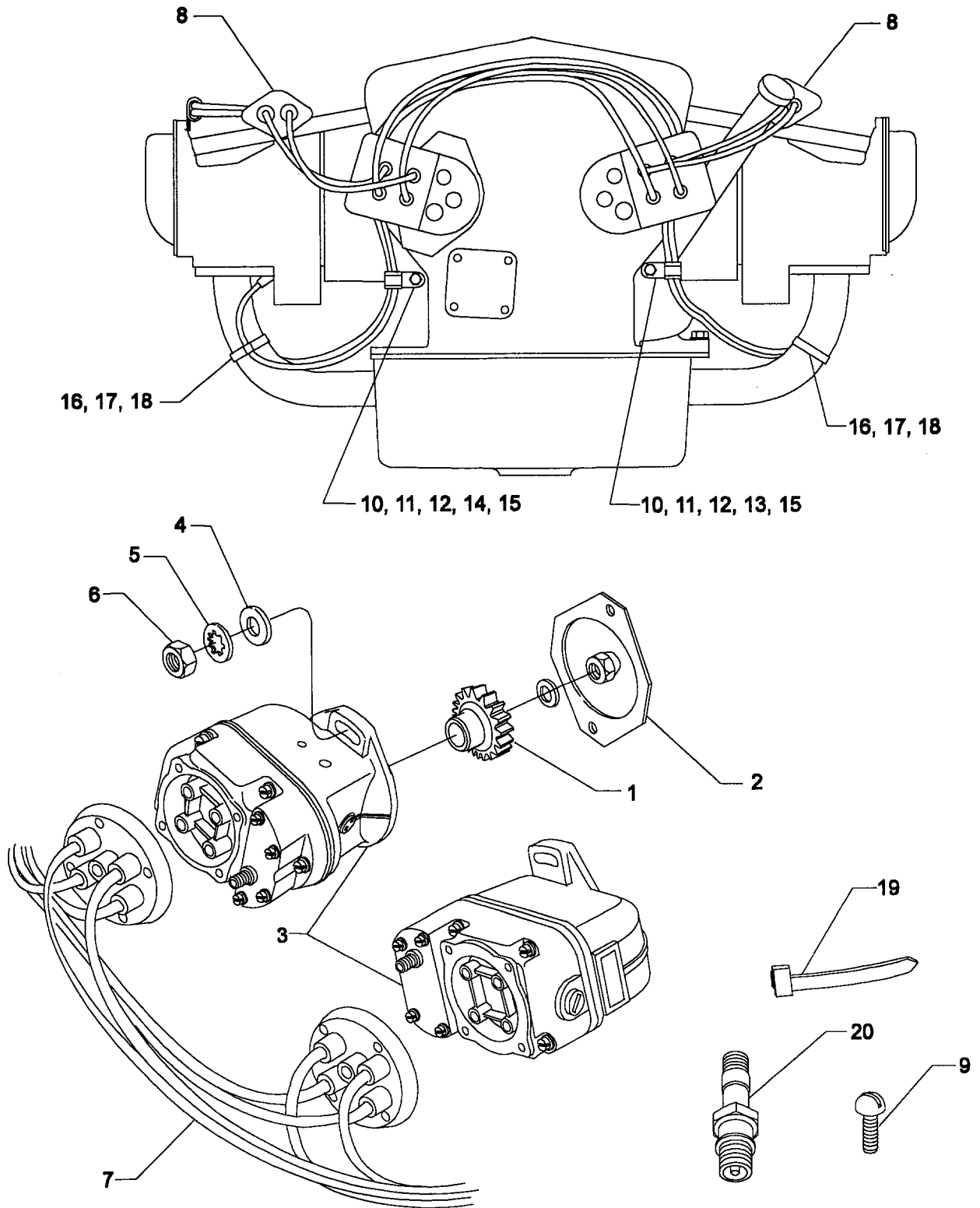

Figure 15. MAGNETOS, MAGNETO DRIVES, HARNESSES AND SPARK PLUGS

SECTION

5

ELECTRICAL SYSTEM

**ELECTRICAL SYSTEM
STARTER AND ATTACHING PARTS**

FIG. REF. 16	PART NUMBER	DESCRIPTION	QTY. PER ASSY.
ATTACHING HARDWARE:			
	STD-35	WASHER, 5/16 plain	4
	STD-475	WASHER, 5/16 lock, internal teeth	4
	LW-31-1.16	BOLT, 5/16-18 x 1-5/32 long, hex. hd.	1
	STD-1410	NUT, 5/16-18 plain	3

**Starter
To Be Supplied
by Airframe Manufacturer**

**ELECTRICAL SYSTEM
ALTERNATOR ASSEMBLY AND BELT**

FIG. REF. 17	PART NUMBER	DESCRIPTION	QTY. PER ASSY.
1	LW-14371	ALTERNATOR ASSY., 12 volt, 60 amp.	1
2	LW-14313	ALTERNATOR, (ALY-8420-LS)	1
3	36B19484	PULLEY, Alternator	1

NOTE

Refer to the latest edition of Textron Lycoming Service Instruction No. 1154 for complete listing of FAA approved starters, generators, alternators, regulators and relays.

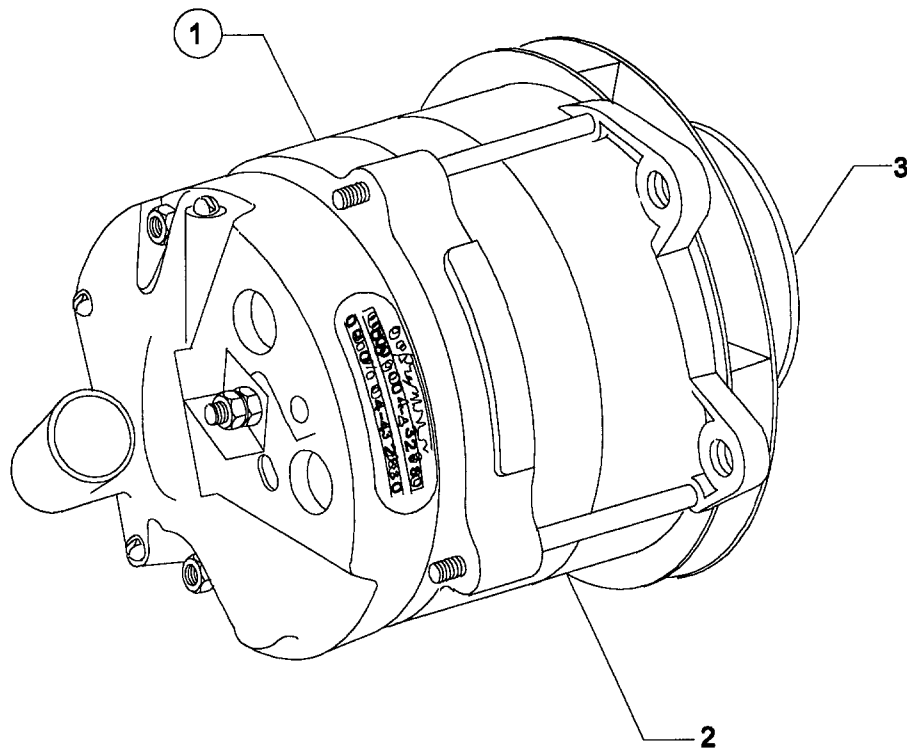
**Figure 17. ALTERNATOR ASSEMBLY AND BELT**

**ELECTRICAL SYSTEM
ALTERNATOR MOUNTING AND ATTACHING PARTS**

FIG. REF. 18	PART NUMBER	DESCRIPTION	QTY. PER ASSY.
1	07A19474	BRACKET, Alternator	1
2	73383	LOCKPLATE, 5/16 bolt x 1.00 spacing	1
3	LW-31-0.94	BOLT, 5/16-18 x 15/16 long, hex. hd.	2
4	75380	LINK, Alternator adjusting	1
5	STD-35	WASHER, 5/16 plain	1
6	LW-31H0.75	BOLT, 5/16-18 x 3/4 long, hex. hd..	1
7	STD-1727	WASHER, Plain, 3/4 O.D. x 11/32 I.D. x 1/8 thick	1
8	LW-31H0.75	BOLT, 5/16-18 x 3/4 long, hex. hd..	1
9	74323	STRUT, Alternator support	1
10	LW-31H0.75	BOLT, 5/16-18 x 3/4 long, hex. hd.	1
11	STD-690	WASHER, 13/16 O.D. x 25/64 I.D. x 1/16 thick	1
12	AN6-14	BOLT, 3/8-24 x 1-37/64 long, hex. hd., drilled end	1
13	STD-690	WASHER, 13/16 O.D. x 25/64 I.D. x 1/16 thick	1
14	STD-872	NUT, 3/8-24 slotted	1
15	STD-713	COTTER PIN, 3/32 dia. x 3/4 long	1
16	AN6-16	BOLT, 3/8-24 x 1-53/64 long, hex. hd., drilled end	1
17	76534	SHIM, 1-1/8 O.D. x 13/32 I.D. x .005 thick	AR
18	STD-690	WASHER, 13/16 O.D. x 25/64 I.D. x 1/16 thick	AR
19	STD-872	NUT, 3/8-24 slotted	1
20	STD-713	COTTER PIN, 3/32 dia. x 3/4 long	1

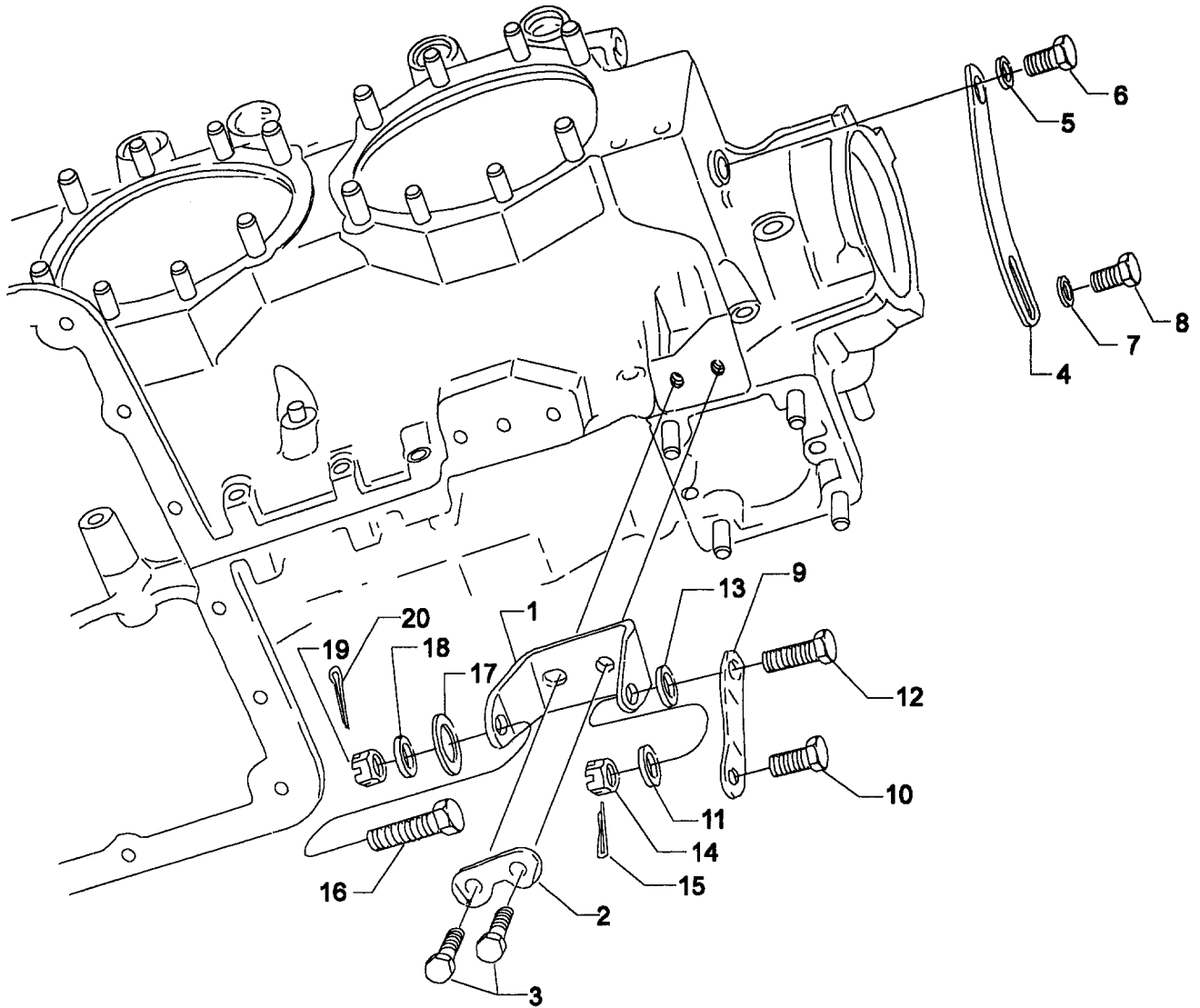

Figure 18. ALTERNATOR MOUNTING AND ATTACHING PARTS

SECTION

6

**OIL SUMP AND
INDUCTION SYSTEM**

**OIL SUMP AND INDUCTION SYSTEM
OIL SUMP ASSEMBLY AND OIL SUCTION SCREEN**

FIG. REF. 19	PART NUMBER	DESCRIPTION	QTY. PER ASSY.
1	LW-13353	GASKET, Oil sump	1
2	78915	SUMP ASSEMBLY, Oil	1
3	78914	CONNECTION, Intake pipe	4
4	61400	STUD, 1/4-20 x 1-3/16 long	4
5	31C-15	STUD, 5/16-18 x 1-7/8 long	4
6	STD-91	PLUG, 1/2-14 NPT, Allen hd.	1
7	STD-551	PLUG, 1/2-14 NPT, Sq. hd., drilled	2
8	STD-8	WASHER, 1/4 plain	28
9	STD-160	WASHER, 1/4 lock, internal teeth	20
10	LW-25-0.94	BOLT, 1/4-20 x 15/16 long, hex. hd.	14
11	LW-25-1.13	BOLT, 1/4-20 x 1-1/8 long, hex. hd.	2
12	STD-1411	NUT, 1/4-20 plain	12
13	STD-2229	PLUG, 1/2 NPT, Allen hd.	2
14	70484	SCREEN, Oil suction	1
15	06E19769-1.00	GASKET, 1.00 I.D. x 1-1/4 O.D. x 3/32 annular	1
16	LW-12545	PLUG, 5/8 hex. hd. x 1.00-20 thread	1

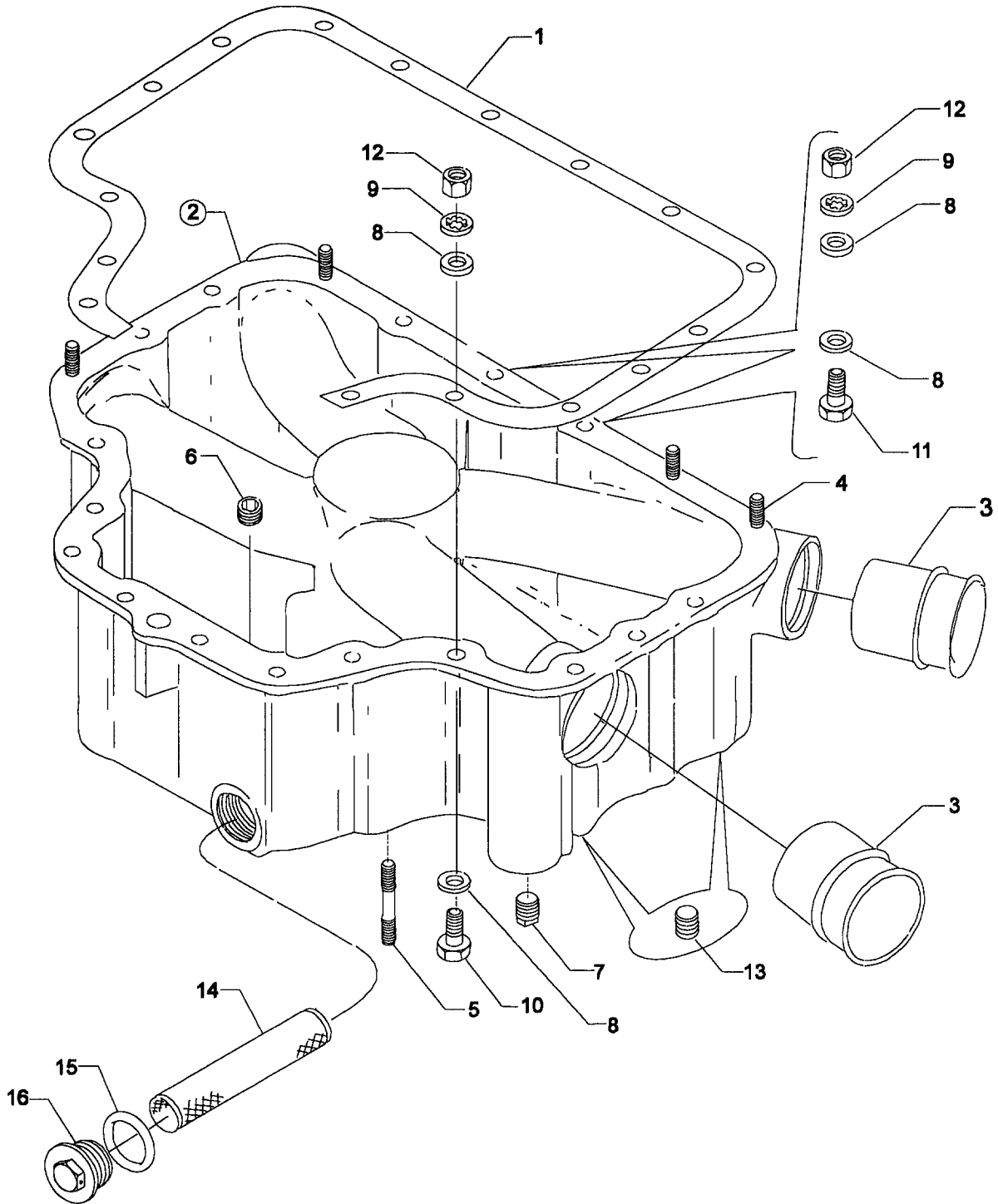

Figure 19. OIL SUMP ASSEMBLY AND OIL SUCTION SCREEN

**OIL SUMP AND INDUCTION SYSTEM
INTAKE PIPES AND ATTACHING PARTS**

FIG. REF. 20	PART NUMBER	DESCRIPTION	QTY. PER ASSY.
1	70485	PIPE, Intake, all cylinders	4
2	69603	HOSE, 1-3/4 I.D. x 2-3/16 O.D. x 1-3/4 long	4
3	LW-15592-8-28	CLAMP, Hose	8
4	71973	GASKET, 2 bolt flange, 1-3/4 I.D.	4
5	73346	FLANGE, Intake pipe, upper	4
6	STD-8	WASHER, 1/4 plain	8
7	STD-160	WASHER, 1/4 lock, internal teeth	8
8	LW-25-1.25	BOLT, 1/4-20 x 1-1/4 long, hex. hd.	8

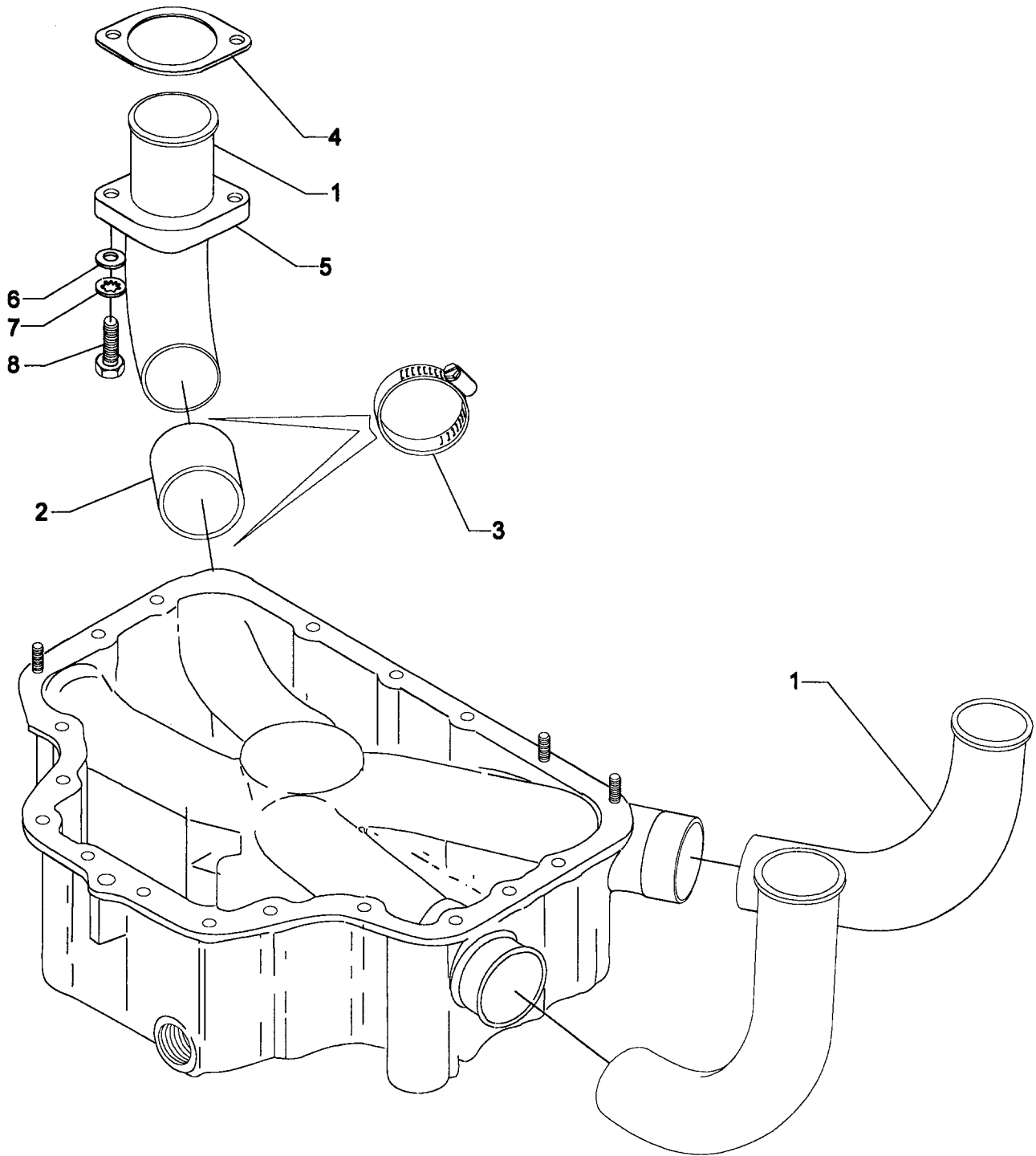

Figure 20. INTAKE PIPES AND ATTACHING PARTS

**OIL SUMP AND INDUCTION SYSTEM
CARBURETOR ASSEMBLY**

FIG REF. 21	PART NUMBER	DESCRIPTION	QTY. PER ASSY.
1	66224	GASKET, Carburetor	1
2	61C22198	CARBURETOR, MA 4-5 (10-6045)	1
	LW-15986	CARBURETOR, MA-4SPA (10-5217)	1
3	STD-35	WASHER, 5/16 plain	4
4	STD-475	WASHER, 5/16 lock, internal teeth	4
5	STD-1410	NUT, 5/16-18 plain	4

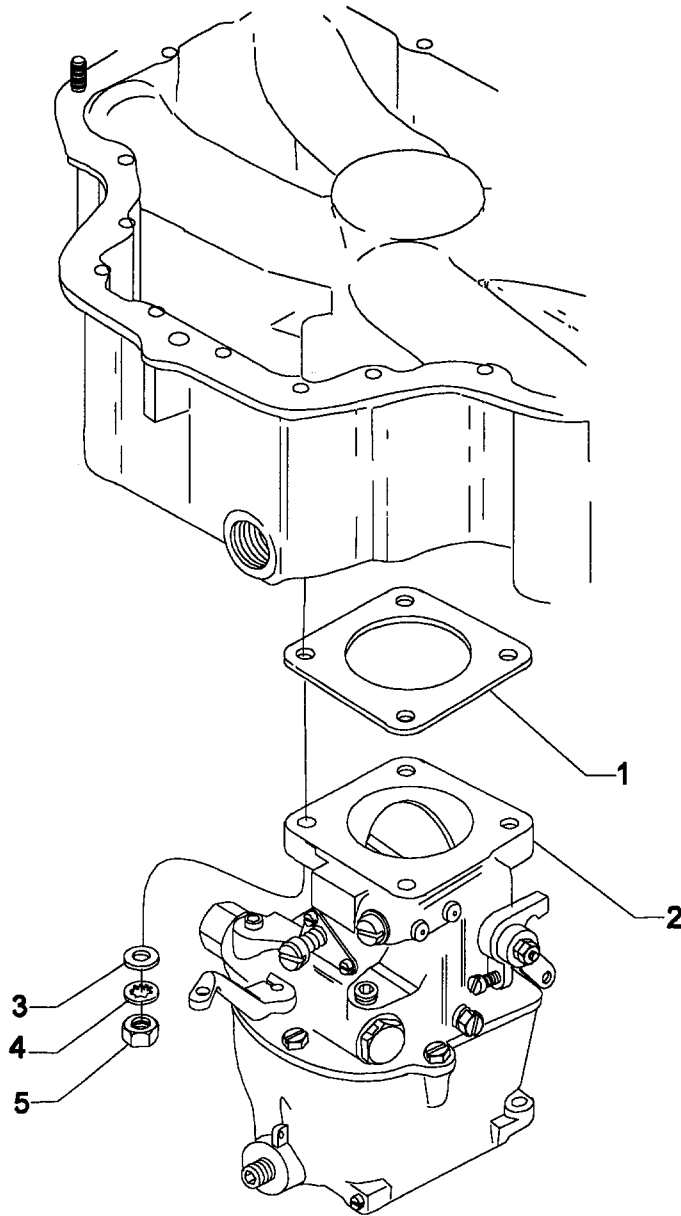

Figure 21. CARBURETOR ASSEMBLY

SECTION

7

**SERVICE KIT
SECTION**

SERVICE KIT SECTION SEAL AND GASKET SET

Part No.	Part Name	Qty
75439-1	SEAL AND GASKET SET	1
AN901-8A	GASKET, Metal tube connect seal	1
LW-10332	LOCKPLATE, Crankshaft gear	1
LW-12272	LOCKPLATE, Shroud tube	4
LW-12681	GASKET, Magneto	2
LW-12795	GASKET, Oil filter adapter	1
LW-13353	GASKET, Oil sump	1
LW-13792	SEAL, Crankshaft oil	1
LW-14260	SEAL, Tachometer drive oil	1
LW-14995	SPRING, Shroud tube	4
LW-18639	LOCKPLATE, Crankshaft gear	1
LW-18661	SEAL, Shroud tube	8
LW-19296	GASKET, Exhaust flange	4
STD-475	WASHER, 5/16 lock, internal teeth	4
STD-213	SEAL, Oil	1
06A19956	SEAL, Oil	1
06E19769-1.00	GASKET, Oil suction screen	1
06E19769-0.63	GASKET, Annular	2
06E19769-1.25	GASKET, Annular	1
1691-C	GASKET, Fuel pump	1
60096	GASKET, Fuel pump	1
61173	GASKET, Oil pressure housing	1
61183	GASKET, Accessory adapter	1
62224	GASKET, Magneto adapter	3
66224	GASKET, Carburetor	2
68315	GASKET, Accessory drive adapter	1
69164	GASKET, Fuel pump adapter	1
69345	SPACER	4
69551	GASKET, Accessory drive adapter	1
70310	SEAL, Shroud tube	8
70455	GASKET	1
71481	RING, Oil seal	4
71973	GASKET, 2 bolt flange	4
72053	GASKET, Governor	2
72059	GASKET, Oil filler extension	1
72075	SEAL, Oil	6
72078	LOCKPLATE, Cam gear	2
72091	RING, Oil seal	2
72220	GASKET, Oil level gage	1
72312	RING, Oil seal	1
72829	LOCKPLATE	1
73189	GASKET	1
73383	LOCKPLATE, Generator bracket	2
73817	LOCKPLATE	2
73818	GASKET, Accessory housing	1
74065	RING, Oil level gage	1
74068	RING, Oil level gage	1
75906	GASKET, Rocker box cover	4
76510	GASKET	1
76940	SEAL, Crankshaft oil	1
77154	GASKET, Carburetor	1
77611	GASKET, Exhaust flange	1
8313	GASKET, Vacuum pump	1

SERVICE KIT SECTION CYLINDER, PISTON AND RING ASSEMBLY

Part No.	Part Name	Qty.
05K21745	KIT - CYLINDER, PISTON AND RING ASSY.	1
LW-13870	CYLINDER AND HEAD ASSEMBLY	1
LW-19001	VALVE, Exhaust	1
73938	VALVE, Intake	1
LW-11800	SPRING, Valve, outer	2
LW-11795	SPRING, Valve, inner	2
LW-10077	SEAT, Valve spring, upper, intake	1
LW-16475	SEAT, Valve spring, upper, exhaust	1
65441	SEAT, Valve spring, lower, intake	1
LW-13323	SEAT, Valve spring, lower, exhaust	1
60009	KEY, Valve, intake	2
17C21191	KEY, Valve, exhaust	2
17C19386	CAP, Valve stem, exhaust	1
75089	PISTON	1
74241	RING, Piston, compression	2
14H21950	RING, Piston, oil regulating	1
LW-14077	PIN, Piston	1
LW-11775	PLUG, Piston pin	2
71481	RING, Cylinder base seal	1
LW-18661	SEAL, Shroud tube	2
70310	SEAL, Shroud tube	2
75906	GASKET, Rocker box cover	1
77611	GASKET, Exhaust	1
71973	GASKET, 2 bolt	1

SERVICE KIT SECTION CRANKCASE ASSEMBLY AND GOVERNOR THRU STUD KITS

Part No.	Part Name	Qty.
11B20061-3SL-S	CRANKCASE ASSEMBLY AND GOVERNOR STUD KIT	1
11B20061-3SL	CRANKCASE ASSEMBLY	1
76220	THRU STUD	4
74887	SPACER	2
STD-2090	NUT, 1/2-20 plain	2
1102	PLUG, 1/8 pipe	6
STD-1339	PLUG, 1/16 pipe	4
SSP-582	TAG (Thin wall bearing)	1
SSP-272	TAG (Piston cooling nozzles)	1

SECTION

8

NUMERICAL INDEX

NUMERICAL INDEX

PART NO.	PART NAME	PAGE NO.	PART NO.	PART NAME	PAGE NO.
AN365-632A	Nut	4-1	LW-13793	Stud	1-1
AN6-14	Bolt	5-3	LW-13796	Shaft	1-7
AN6-16	Bolt	5-3	LW-13870	Cyl. & Head Assy.	3-3
AN6-34A	Bolt	1-9	LW-13884	Bearing	1-3
AN960-616L	Washer	1-9	LW-13923	Bushing	3-1
LW-25-0.94	Bolt	2-3	LW-14060	Pin	3-1
LW-25-0.94	Bolt	6-1	LW-14260	Seal	2-3
LW-25-1.13	Bolt	1-9	LW-14313	Alternator	5-2
LW-25-1.13	Bolt	2-3	LW-14371	Alternator Assy.	5-2
LW-25-1.13	Bolt	6-1	LW-14793	Gage Assy.	1-3
LW-25-1.25	Bolt	4-1	LW-14995	Spring	3-7
LW-25-1.25	Bolt	6-3	LW-15592-5-05	Clamp	3-9
LW-25-1.50	Bolt	1-9	LW-15592-8-28	Clamp	6-3
LW-25-1.50	Bolt	2-3	LW-15839	Baffle Assy.	3-9
LW-25-1.75	Bolt	1-9	LW-15970	Tube	1-3
LW-25S1.50	Bolt	1-9	LW-16475	Seat	3-7
LW-31-0.94	Bolt	5-3	LW-16711	Bearing	1-3
LW-31-1.16	Bolt	5-1	LW-18085	Spring	1-3
LW-31H0.75	Bolt	5-3	LW-18639	Lockplate	1-5
LW-31H0.88	Bolt	1-7	LW-18661	Seal	3-7
LW-38-0.75	Bolt	2-5	LW-18667	Pin	1-7
LW-M-2375	Plate	4-1	LW-18840	Camshaft Assy.	1-7
LW-M-2403	Harness Assy.	4-1	LW-18959-175-25	Clamp	4-1
LW-M-2404	Harness Assy.	4-1	LW-19001	Valve	3-7
LW-10077	Seat	3-7	MS20823-6D	Elbow	3-3
LW-11485	Shroud Tube Assy.	3-7	STD-8	Washer	1-9
LW-11713	Spring	1-3	STD-8	Washer	2-3
LW-11750-S	Conn. Rod Assy.	3-1	STD-8	Washer	2-5
LW-11775	Plug	3-1	STD-8	Washer	2-7
LW-11795	Spring	3-7	STD-8	Washer	4-1
LW-11800	Spring	3-7	STD-8	Washer	6-3
LW-11997	Seal	1-3	STD-33	Washer	1-9
LW-12186	Nut	3-1	STD-33	Washer	2-5
LW-12272	Lockplate	3-7	STD-35	Washer	2-3
LW-12545	Plug	6-1	STD-35	Washer	2-5
LW-12892	Thrust Button	3-5	STD-35	Washer	3-3
LW-13323	Seat	3-7	STD-35	Washer	5-1
LW-13353	Gasket	6-1	STD-35	Washer	5-3
LW-13521	Bearing	3-1	STD-35	Washer	6-5
LW-13790	Shaft	3-5	STD-91	Plug	6-1
LW-13792	Seal	1-3	STD-160	Washer	1-9

NUMERICAL INDEX (Continued)

PART NO.	PART NAME	PAGE NO.	PART NO.	PART NAME	PAGE NO.
STD-160	Washer	2-3	STD-1411	Nut	4-1
STD-160	Washer	2-5	STD-1411	Nut	6-1
STD-160	Washer	4-1	STD-1420	Nut	2-3
STD-160	Washer	6-1	STD-1623	Insert	1-1
STD-160	Washer	6-3	STD-1727	Washer	4-1
STD-475	Washer	2-5	STD-1727	Washer	5-3
STD-475	Washer	3-3	STD-1821	Hose	3-9
STD-475	Washer	4-1	STD-1856	Screw	2-7
STD-475	Washer	5-1	STD-1916	Screw	4-1
STD-475	Washer	6-5	STD-1925	Screw	3-9
STD-514	Dowel	1-1	STD-2090	Nut	3-5
STD-551	Plug	6-1	STD-2168	Nut	1-7
STD-553	Screw	4-1	STD-2213	Screw	1-5
STD-557	Dowel	1-1	STD-2229	Plug	6-1
STD-596	Nut	1-9	STD-2231	Ring	1-7
STD-619	Washer	1-1	25C-8	Stud	3-3
STD-678	Washer	1-9	31C-12	Stud	1-1
STD-678	Washer	2-5	31C-12	Stud	2-1
STD-684	Nipple	3-9	31C-12	Stud	3-3
STD-690	Washer	5-3	31C-13	Stud	1-1
STD-713	Cotter Pin	5-3	31C-15	Stud	6-1
STD-783	Plug	2-5	31CD-17	Stud	2-1
STD-784	Plug	2-1	38-13	Stud	1-1
STD-784	Plug	2-7	38D-17	Stud	1-1
STD-872	Nut	1-9	50-15	Stud	1-1
STD-872	Nut	5-3	383-B	Nut	3-5
STD-1065	Dowel	1-5	1028-B	Ball	1-3
STD-1211	Plug	1-5	1102	Plug	1-1
STD-1339	Plug	1-1	1102	Plug	2-1
STD-1353	Insert	3-3	1102	Plug	3-3
STD-1409	Nut	1-9	1182-E7	Spark Plug	4-1
STD-1410	Nut	2-5	60009	Key	3-7
STD-1410	Nut	3-3	60096	Gasket	2-5
STD-1410	Nut	4-1	60430	Cover	2-5
STD-1410	Nut	6-5	60803	Strap	1-9
STD-1410	Nut	3-9	61084	Spring	1-3
STD-1411	Nut	1-9	61173	Gasket	2-7
STD-1411	Nut	2-5	61174	Shaft	2-3
STD-1411	Nut	3-7	61183	Gasket	2-5

NUMERICAL INDEX (Continued)

PART NO.	PART NAME	PAGE NO.	PART NO.	PART NAME	PAGE NO.
61247	Cover	3-9	73437	Rod Assy.	3-5
61400	Stud	2-1	73818	Gasket	2-1
61400	Stud	6-1	73938	Valve	3-7
61681	Guide, Intake	3-3	74068	"O" Ring	1-3
62224	Gasket	4-1	74230	Guide, Exhaust	3-3
62417	Plug	2-7	74241	Ring	3-1
62817	Screen Assy.	2-7	74323	Strut	5-3
65098	Cover	2-5	74637	Bushing	3-5
65441	Seat	3-7	74887	Spacer	3-5
66224	Gasket	6-5	74996	Gear Assy.	1-7
66610	Bushing	3-3	75089	Piston	3-1
66796	Insert	3-3	75061	Bolt	3-1
68668	Spring	1-3	75154	Stud	1-1
68759	Tube Assy.	3-9	75380	Link	5-3
68760	Tube Assy.	3-9	75906	Gasket	3-9
68761	Tube Assy.	3-9	76118	Spacer	1-7
69106	Cover	2-5	76121	Shaft Assy.	1-7
69510	Screen Housing	2-7	76220	Stud	1-9
69551	Gasket	2-5	76510	Gasket	2-7
69603	Hose	6-3	76534	Shim	5-3
69796	Dowel	1-1	76734	Zip Strap	4-1
70310	Seal	3-7	77309	Bushing	1-7
70484	Screen	6-1	77467	Spring	1-3
70485	Intake Pipes	6-3	77611	Gasket	3-3
71032	Bushing	1-1	77808	Valve Assy.	1-3
71140	Breather Fitting	2-7	78290	Plunger Assy.	3-7
71481	Ring	3-5	78531	Oil Pump Body	2-3
71611	Retainer	3-9	78914	Connection	6-1
71629	Hook	3-9	78915	Sump Assy.	6-1
71710	Carburetor	6-5	01K22155-S	Bushing	1-5
71973	Gasket	6-3	01K22156-S	Bushing	1-5
72057	Seat	3-3	05K19423-S	Impeller Kit	2-3
72058	Seat	3-3	06E19769-0.63	Gasket	2-5
72059	Gasket	1-3	06E19769-0.63	Gasket	2-7
72075	Seal	1-3	06E19760-1.00	Gasket	6-1
72091	Ring	1-3	06E19769-1.24	Gasket	1-3
72351	Screw	4-1	07A19474	Bracket	5-3
72566	Gear	1-5	11B20061-3SL	Crankcase Assy.	1-1
72877	Body	1-3	13S19646	Gear	1-5
73346	Flange	6-3	13B27143	Crk'sft & Bush. Assy.	1-5
73383	Lockplate	5-3	14H21950	Ring	3-1

NUMERICAL INDEX (Continued)

PART NO.	PART NAME	PAGE NO.
15B21319	Socket	3-7
15F19957-34	Rod Assy.	3-5
15F19957-35	Rod Assy.	3-5
15F19957-36	Rod Assy.	3-5
17C19386	Cap	3-7
17C21191	Key	3-7
17F19357	Rocker Assy.	3-5
18A19441	Bearing	1-3
21A21533-03	Housing Assy.	2-1
31M21994	Support Assy.	1-5
36B19484	Pulley	5-2
53E22144	Valve Assy.	2-7
66B21772	Magneto	4-1
66B21779	Magneto	4-1
68C19622	Gear	4-1